



GE Industrial Systems

AC Motor Selection and Application Guide



TABLE OF CONTENTS

Voltage 2
 Frequency 3
 Phase 4
 Motor Output Rating 4
 Polyphase Motors 4
 Single-phase Motors 4
 Service Factor 9
 Motor Temperature 9
 Duty Cycle Application 11
 Starting 12
 Efficiency 12
 Power Factor 13
 Load Connection 14
 Electrical and Mechanical Construction 15
 Model List Nomenclature 19
 Modifications, Electrical 19
 Modifications, Mechanical 21
 Modifications, Environmental 23
 Special and Definite Purpose Applications 24

INDEX

Altitude 23
 Ambient 23
 Balance, Dynamic 16
 Bearing Systems, Horizontal 16
 Bearing Thermal Protection 21
 Brake 21
 C-Face Mounting 22
 Closed Coupled Pump Motor 24
 Connection, Winding 15
 Conduit Box, Special 21
 Cooling 10
 Couplings, Half 21
 Current, General 5
 Current, Low Starting 20
 Current Transformer 19
 D Flange Mounting 22
 Design A & B (Type K & KS) 6
 Design C (Type KG & KGS) 6
 Design D (Type KR) 7
 Design L (Type KC) 9
 Design Comparison, Polyphase 7
 Dowel Holes 21
 Drains and Breathers 16
 Drip Covers 23
 Duty Cycle Application 11
 Dynamic Balance 16
 Efficiency, High 12
 Elevator Motors 25
 Enclosures 17
 Enclosure, Materials 15
 Endshields, Special 22
 Explosion-Proof Motors 18
 Export Boxing 23
 Extra Severe-Duty Motors 24
 Frame, Non-standard 22
 Frequency, Definition 3
 Frequency, Dual 4
 Frequency, Standards 3

Frequency, Variation 2
 50 Hertz Operation 4
 Grease Fittings 22
 Grease, Special 23
 Grounding 20
 Hardware 23
 Hazardous Locations 18
 Horsepower 4
 Hydraulic Elevator Motors 25
 Inertia, Load 12
 Injection Molding Motors 26
 Insulation Class 10
 Leads, Special 20
 Load Connection 14
 Load, High Inertia 12
 Losses, General 13
 Losses, Type of 13
 Lubrication 17
 Model List Nomenclature 19
 Mounting Configurations 16
 Multispeed Motors 26
 Oil Well Pumping Motors 27
 Paint, Standard 23
 Polyphase, Design Comparison 7
 Polyphase Motors, 1-200 Hp 6
 Polyphase Motors, 500 Hp & Up 9
 Power Factor 13
 Power, Polyphase 4
 Power, Single-phase 4
 Seals, Shaft 23
 Shafts, Special 22
 Screens 24
 Sheave, Limiting Dimensions 14
 Service Factor 9
 Single-phase Motors 9
 Single-phase Power 4
 Speed, RPM 4
 Starting Frequency 12
 Starting Connections 15
 Surge Protection 20
 TEAO Motors 28
 Temperature Rise, Special 20
 Testing 13
 Thermal Protection 20
 Terminals, Special 20
 Torque 4
 Torque, Breakdown 5
 Torque, Definition 5
 Torque, Locked-rotor 5
 Torque, Pull-up 5
 Type K and KS Motors (Design A & B) 6
 Type KC Motors (Design L) 9
 Type KR Motors (Design D) 7
 Variable Frequency Drives 4
 Voltage 2
 Voltage, Definition 2
 Voltage, Low Starting 3
 Voltage, Special 2
 Voltage, Unbalance 3
 Voltage, Variation 2
 Winding Treatment, Special 18

VOLTAGE

DEFINITION

The motor nameplate voltage is determined by the available power supply which must be known in order to properly select a motor for a given application. The nameplate voltage will normally be less than the nominal distribution system voltage.

The distribution voltage is the same as the supply transformer voltage rating; the utilization (motor nameplate) voltage is set at a slightly lower level to allow for a voltage drop in the system between the transformer and the motor leads.

Some specifications still call for 220, 440 or 550 volt motors which were the long accepted standards. However, modern distribution systems have transformers located adjacent to secondary unit substations or load centers, plant wide power factor correction and shorter power line runs. The result is a stiffer distribution system which delivers higher voltage at the motor. The following motor nameplate voltages provide the best match to distribution system voltages and meet current motor design practices.

Table 1. Standard 60 hertz Nameplate Voltages

Nominal Distribution System Voltage	Motor Nameplate Voltage	
	Below 125 Hp	125 Hp and Up
Polyphase 60 hertz		
208	200	—
240	230	—
480	460	460
600	575	575
2400	2300	2300
4160	4000	4000
Single-phase 60 hertz		
120	115	—
208	200	—
240	230	—

Table 2. Standard 50 hertz Nameplate Voltages

Nominal Distribution System Voltage	Motor Nameplate Voltage	
	Below 125 Hp	125 Hp and Up
Polyphase 50 hertz		
See Note	200	—
	220	—
	380	380
	415	415
	440	440
	550	550
	3000	3000
Single-phase 50 hertz		
See Note	110	—
	200	—
	220	—

NOTE: Distribution system voltages vary from country to country; therefore, motor nameplate voltage should be selected for the country in which it will be operated.

SPECIAL VOLTAGES

Special motor designs are required for nameplate voltages other than those listed in Tables 1 & 2. Motors greater than 100 horsepower rated less than 345 volts will not be furnished without approval of the Company. Motors with nameplate voltages different than those listed in Tables 1 or 2 should be referred to the Company.

DUAL VOLTAGE MOTORS

Polyphase and single-phase motors may be furnished as dual voltage ratings under the following conditions:

- Both voltages are standard for the particular rating as listed in Tables 1 and 2.
- The two voltages are in a ratio of either 1:2 or 1:√3 (e.g. 230/460, 60 Hz; 2300/4000, 60 Hz; or 220/380, 50 Hz).
- Single-phase voltage ratios are 1:2 only.

VOLTAGE AND FREQUENCY VARIATION

All motors are designed to operate successfully with limited voltage and frequency variations. However, voltage variation with rated frequency must be limited to ±10% and frequency variations with rated voltage must be limited to ±5%. The combined variation of voltage and frequency must be limited to the arithmetic sum of 10%. Variations are expressed as deviation from motor nameplate values, not necessarily system nominal values. The allowable ±10% voltage variation is based upon the assumption that horsepower will not exceed nameplate rating and that motor temperature may increase. For instance, a 230 volt motor operating at 207 volts (90% of rated) loses any service factor indicated on the nameplate, and could run hotter than at rated voltage.

The following conditions are likely to occur with variations in voltage:

- An increase or decrease in voltage may result in increased heating at rated horsepower load. Under extended operation this may accelerate insulation deterioration and shorten motor insulation life.
- An increase in voltage will usually result in a noticeable decrease in power factor. Conversely, a decrease in voltage will result in an increase in power factor.
- Locked-rotor and breakdown torque will be proportional to the square of the voltage. Therefore, a decrease in voltage will result in a decrease in available torque.
- An increase of 10% in voltage will result in a reduction of slip of approximately 17%. A voltage reduction of 10% would increase slip by about 21%.

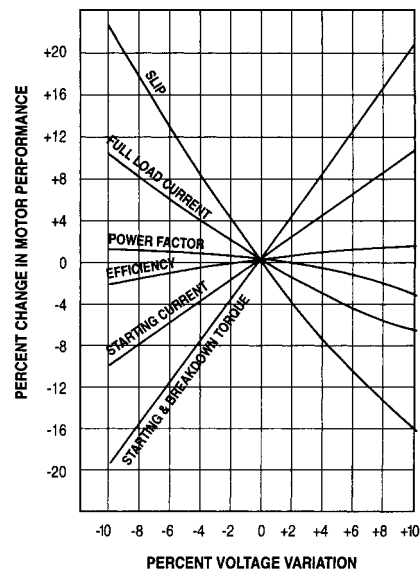

Figure 1. Voltage Variation

The following conditions are likely to occur with variations in frequency:

- A. Frequency greater than rated frequency normally improves power factor but decreases locked-rotor and maximum torque. This condition also increases speed, and therefore, friction and windage losses.
- B. Conversely, a decrease in frequency will usually lower power factor and speed while increasing locked-rotor maximum torque and locked-rotor current.

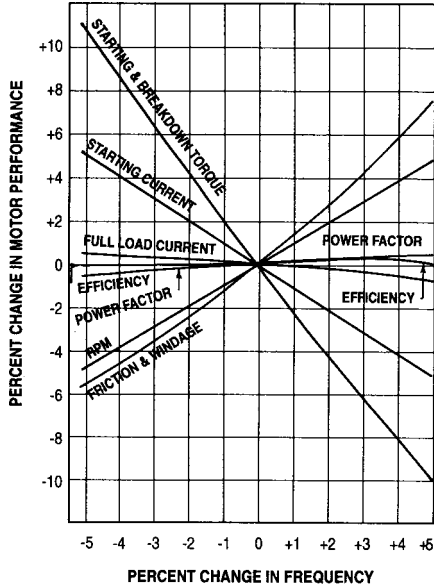

Figure 2. Frequency Variation

VOLTAGE UNBALANCE

Unbalanced line voltages applied to a polyphase motor result in unbalanced currents in the stator windings. Even a small percentage of voltage unbalance will result in a larger percentage of current unbalance, thus increasing temperature rise and possibly result in nuisance tripping.

Voltages should be as evenly balanced as can be read on a voltmeter. If voltages are unbalanced, the rated horsepower of the motor should be derated, based upon the percent unbalance, as shown in the following graph

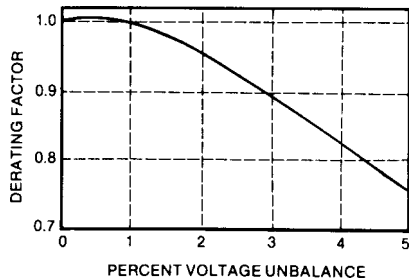

Figure 3. Voltage Unbalance

Percent voltage unbalance is calculated as follows:

$$\text{Percent Unbalance} = 100 \times \frac{\text{Maximum Voltage Deviation From Average Voltage}}{\text{Average Voltage}}$$

For instance, a 100 horsepower, three-phase motor operating with voltages of 598, 575 and 552 applied at the motor terminals is running with a 4% voltage unbalance ($100 \times 23/575$). Consequently, the rated output of 100 horsepower should be derated to approximately

82 Hp to reduce the possibility of damage to the motor. *Motor operation above 5% voltage unbalance is not recommended.*

Unbalanced voltages will produce the following effects on performance characteristics:

- Torques: Unbalanced voltage results in reduced locked-rotor and breakdown torques for the application.
- Full-Load Speed: Unbalanced voltage results in a slight reduction of full-load speed.
- Current: Locked-rotor current will be unbalanced to the same degree that voltages are unbalanced but locked-rotor KVA will increase only slightly. *Full-load current at unbalanced voltage will be unbalanced in the order of six to ten times the voltage unbalance.*
- Temperature Rise: A 3.5% voltage unbalance will cause an approximate 25% increase in temperature rise.

LOW STARTING VOLTAGE

Large motors may experience a considerable voltage drop at the motor terminals when started due to large inrush current values. Motors can be designed to compensate for this drop in voltage. For example, motors in frames 182-5013 can be supplied for operation under low starting voltage conditions down to 65% of nameplate rated voltage. The inertia referred to the motor shaft, the type of load (constant or variable torque), and the expected voltage drop must be provided to allow evaluation of the application for each rating involved. In any case, motors designed for low starting voltage may have higher than standard inrush current when started on full rated voltage.

FREQUENCY

DEFINITION

Frequency can be defined as the number of complete alterations-per-second of an alternating current.

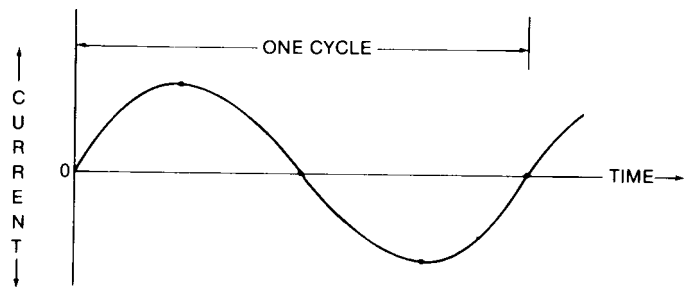

Figure 4.

As shown in Figure 4 above, current is said to have been through one complete cycle when it has gone from zero to maximum, to minimum, and back to zero again. Frequency is the number of these complete cycles over the passage of time and is usually expressed as hertz (Hz): one hertz equals one cycle per second (cps). Predominate frequency in North America is 60 Hz.

FREQUENCY STANDARDS

The predominant frequency in the United States is 60 hertz. However, 50 hertz systems are common in other countries. Other systems, such as 40 and 25 hertz are isolated and relatively few in number.

50 Hz OPERATION OF 60 Hz MOTORS

General Electric standard motors rated at 60 Hz may be successfully operated at 50 Hz at reduced voltage and horsepower as shown in the following table:

Table 3.

Motor Rated 60 hertz Voltage	50 hertz Optional Voltage Ratings (±5%)		
230	190	200	208
460	380	400	415
575	475	500	—
Derate Factor	.85	.90	1.00

- Rated Hp at 50 Hz = Nameplate Hp x Derate Factor
- Allowable voltage variation at derated Hp = ±5%
- Select motor overload protection for 60 Hz Amps and 1.0 Service Factor
- Motor speed = 5/6 nameplate rated speed
- Service Factor = 1.0

Sixty hertz motors intended for use as shown above should be ordered as 60 Hz motors with no reference to 50 Hz operation. A “stick-on” label containing the information shown in Table 3 is available.

DUAL FREQUENCY

Motors that require 50 and 60 Hz operation of the same motor are non-NEMA defined motors and will be nameplated as such. When this is a motor requirement, it must be specified with the order.

VARIABLE FREQUENCY OPERATION

Motors are available for use on variable frequency inverters. Generally speaking, there are three different types of inverters:

1. VVI is a square wave inverter in which voltage and frequency vary in proportion (constant volts per hertz).
2. PWI is a pulse width modulated inverter and the same as the VVI type except pulses are varied in time to simulate a sine wave.
3. CCI is a constant current inverter, which utilizes a square wave current supply as opposed to voltage.

When applying a motor for use with a variable frequency drive, see section on special applications.

POLYPHASE OR SINGLE-PHASE POWER

DEFINITION

A power system can be either single-phase or polyphase. Figure 4 illustrates single-phase power, which is most commonly found in homes, rural areas and in small commercial establishments.

A polyphase power system consists of 2 or more alternating currents of equal frequency and amplitude but offset from each other by a phase angle. Figure 5 illustrates a three-phase power system having phases A, B and C. Each phase is offset by 120 degrees, 360 degrees being the span of one complete cycle.

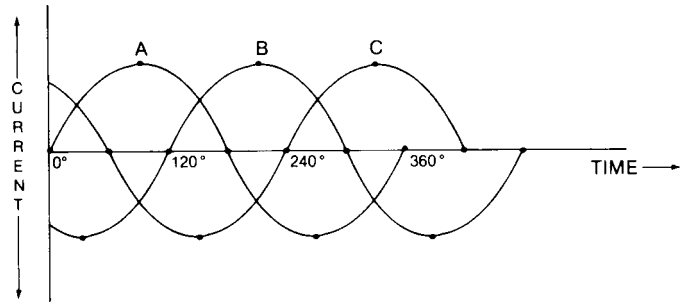

Figure 5. Three-phase Power

For motors, an advantage of three-phase power is simpler construction which requires less maintenance. Also, a more powerful machine can be built into a smaller frame and will generally operate at a higher efficiency than single-phase motors of the same rating.

MOTOR OUTPUT RATING

SPEED

The speed at which an induction motor operates is dependent upon the input power frequency and the number of electrical magnetic poles for which the motor is wound. The higher the frequency, the faster the motor runs. The more poles the motor has, the slower it runs. The speed of the rotating magnetic field in the stator is called synchronous speed. To determine the synchronous speed of an induction motor, the following equation is used:

$$\text{Synchronous Speed (rpm)} = \frac{60 \times 2 \times \text{Frequency}}{\text{Number of poles}}$$

Actual full-load speed (the speed at which an induction motor will operate at nameplate rated load) will be less than synchronous speed. The difference between synchronous speed and full-load speed is called slip. Percent slip is defined as follows:

$$\text{Percent Slip} = \frac{\text{Synchronous Speed} - \text{Full Load Speed}}{\text{Synchronous Speed}} \times 100$$

Induction motors are built having rated slip ranging from less than 5% to as much as 20%. A motor with a slip of less than 5% is called a normal slip motor. Motors with a slip of 5% or more are used for applications requiring high starting torque (conveyor) and/or higher than normal slip (punch press) where, as the motor slows down, increased torque allows for flywheel energy release.

TORQUE & HORSEPOWER

Torque and horsepower are two key motor characteristics that determine the size of motor for an application. The difference between the two can be explained using a simple illustration of a shaft and wrench.

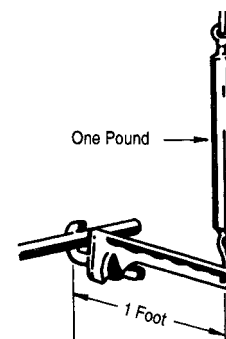

Figure 6.

Torque is merely a turning effort or force acting through a radius. In Figure 6 on page 4, it takes one pound at the end of the one foot wrench to turn the shaft at a steady rate. Therefore, the torque required is one pound times one foot, or one pound-foot. If the wrench were turned twice as fast, the torque required would remain the same, provided it is turned at a steady rate.

Horsepower, on the other hand, take into account how fast the shaft is turned. Turning the shaft rapidly requires more horsepower than turning it slowly. Thus, horsepower is a measure of the rate at which work is done. By definition, the relationship between torque and horsepower is as follows:

$$1 \text{ Horsepower} = 33,000 \text{ Lb-Ft/Minute}$$

In the above example, the one pound force moves a distance of 1 foot x 2π x 1 pound, or 6.28 feet per revolution. To produce one horsepower, the shaft would have to be turned at a rate of:

$$\frac{1 \text{ Hp} \times 33,000 \text{ lb-ft/Min/} \cancel{\text{Hp}}}{1 \text{ lb} \times 2\pi \text{ ft/Revolution}} = 5252 \text{ rpm}$$

From the above, an equation is derived for determining horsepower output from speed and torque in lb-ft.

$$\text{Hp} = \frac{\text{rpm} \times 2\pi \times \text{Torque}}{33,000} \quad \text{or} \quad \text{Hp} = \frac{\text{rpm} \times \text{Torque}}{5252}$$

From this relationship:

$$\text{Full-load torque in lb-ft} = \frac{\text{Hp} \times 5252}{\text{Full-Load rpm}}$$

The following graph illustrates a typical speed torque curve for a NEMA design B induction motor. An understanding of several points on this curve will aid in properly applying motors.

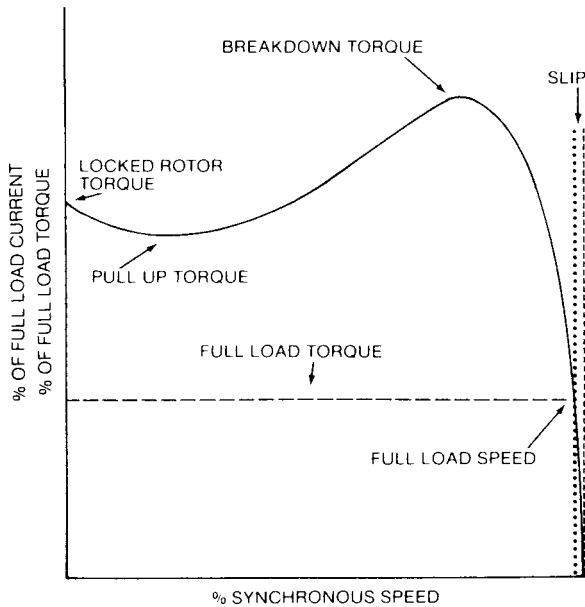

Figure 7. Speed Torque Curve

LOCKED-ROTOR TORQUE

Locked-rotor torque is the torque which the motor will develop at rest (for all angular positions of the rotor) with rated voltage at rated frequency applied. It is also sometimes known as "starting torque" and is usually expressed as a percentage of full-load torque.

PULL-UP TORQUE

Pull-up torque is the minimum torque developed during the period of acceleration from locked-rotor to the speed at which breakdown torque

occurs. For motors which do not have a definite breakdown torque (such as NEMA design D) pull-up torque is the minimum torque developed up to rated full-load speed. It is usually expressed as a percentage of full-load torque.

BREAKDOWN TORQUE

Breakdown torque is the maximum torque the motor will develop with rated voltage applied at rated frequency without an abrupt drop in speed. Breakdown torque is usually expressed as a percentage of full-load torque.

FULL-LOAD TORQUE

Full-load torque is the torque necessary to produce rated horsepower at full-load speed. In pound-feet, it is equal to the rated horsepower times 5252 divided by the full-load speed in rpm.

MOTOR CURRENT

In addition to the relationship between speed and torque, the relationship of motor current to these two values is an important application consideration. The speed/torque curve is repeated below with the current curve added to demonstrate a typical relationship.

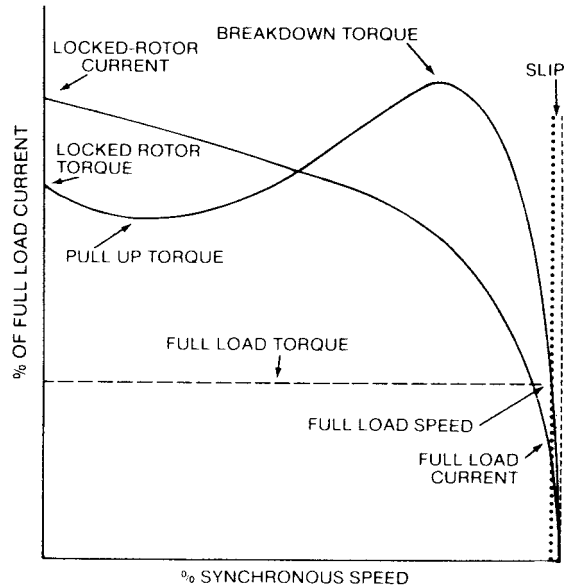

Figure 8. Speed, Torque, Current Curve

Two important points on this current curve need to be examined:

FULL-LOAD CURRENT

The full-load current of an induction motor is the steady-state current taken from the power line when the motor is operating at full-load torque with rated voltage and rated frequency applied.

LOCKED-ROTOR CURRENT

Locked-rotor current is the steady-state current of a motor with the rotor locked and with rated voltage applied at rated frequency. NEMA has designated a set of code letters to define locked-rotor kilovolt-amperes-per-horsepower. This code letter appears on the nameplate of all AC squirrel-cage induction motors. KVA per horsepower is calculated as follows:

For three-phase motors:

$$\text{KVA} = \frac{\sqrt{3} \times \text{current (in amperes)} \times \text{volts}}{1000 \times \text{Hp}}$$

For single-phase motors:

$$\text{KVA/} \cancel{\text{Hp}} = \frac{\text{current (in amperes)} \times \text{volts}}{1000 \times \cancel{\text{Hp}}}$$

Table 4. Locked-Rotor Current Code Letters

Letter Designation	KVA per Hp*
A	0 - 3.15
B	3.15 - 3.55
C	3.55 - 4.0
D	4.0 - 4.5
E	4.5 - 5.0
F	5.0 - 5.6
G	5.6 - 6.3
H	6.3 - 7.1
J	7.1 - 8.0
K	8.0 - 9.0
L	9.0 - 10.0
M	10.0 - 11.2
N	11.2 - 12.5
P	12.5 - 14.0
R	14.0 - 16.0
S	16.0 - 18.0
T	18.0 - 20.0
U	20.0 - 22.4
V	22.4 and up

*The locked-rotor kilovolt-ampere-per-horsepower range includes the lower figure up to, but not including, the higher figure. For example, 3.14 is letter "A" and 3.15 is letter "B".

By manipulating the preceding equation for KVA/Hp for three-phase motors the following equation can be derived for calculating locked-rotor current:

$$LRA = \frac{1000 \times Hp \times \text{Locked-Rotor KVA/Hp}}{\sqrt{3} \times \text{Volts}}$$

This equation can then be used to determine approximate starting current of any particular motor. For instance, the approximate starting current for a 7 1/2 Hp, 230 volt motor with a locked-rotor KVA code letter G would be:

$$LRA = \frac{1000 \times 7.5 \times 6.0}{\sqrt{3} \times 230} = 113 \text{ amps}$$

Operating a motor in a locked-rotor condition in excess of 20 seconds can result in insulation failure due to the excessive heat generated in the stator. Figure 9 illustrates the maximum time a motor may be operated at locked-rotor without injurious heating. This graph assumes a NEMA design B motor with a class B or F temperature rise.

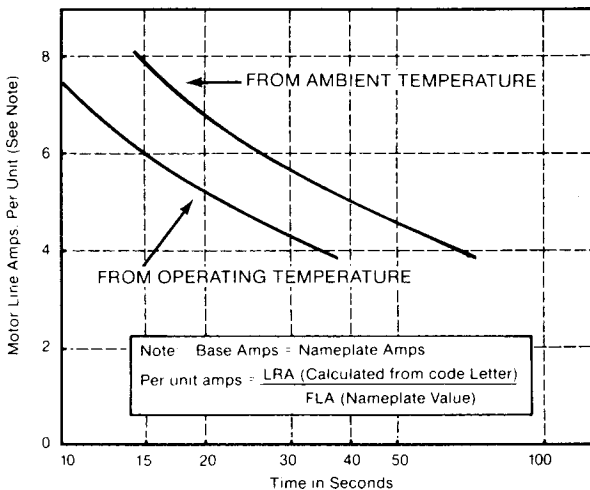

Figure 9. Line Current vs. Safe Stall Time for Standard Induction Motors

Motor protection, either inherent or at the motor control should be selected to limit stall time of the motor.

POLYPHASE MOTORS, 1-200 HP

NEMA has designated several specific types of motors, each type having unique speed/torque relationships. These designs are described below along with some typical applications for each. Following these descriptions is a summary of performance characteristics.

NEMA DESIGN A & B

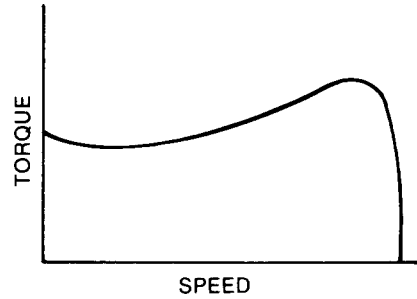

Figure 10. Typical NEMA Design A & B Speed/Torque Curve

- GE Type: K, KS
- Starting Current: Design A - High to Medium (not defined by NEMA) Design B - Low
- Starting Torque: Normal
- Breakdown Torque: Normal
- Full-Load Slip: Low (less than 5%)
- Applications: Fans, blowers, pumps, machine tools, or other uses with low starting torque requirements and essentially constant load.

NEMA DESIGN C

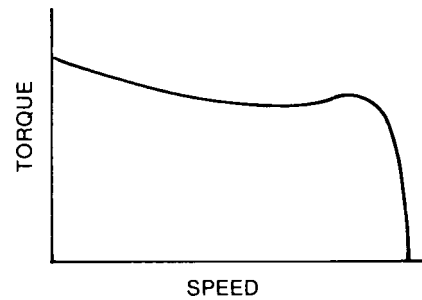

Figure 11. Typical NEMA Design C Speed/Torque Curve

- GE Type: KG, KGS
- Starting Current: Low
- Starting Torque: High
- Breakdown Torque: Normal
- Full-Load Slip: Low (less than 5%)
- Applications: Hard-to-start loads such as plunger pumps, conveyors and compressors.

NEMA DESIGN D

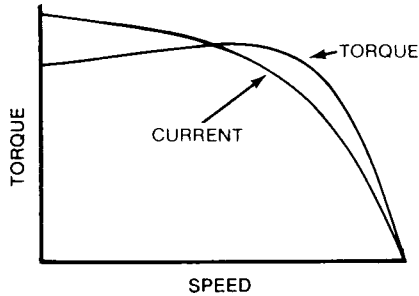

Figure 12. Typical NEMA Design D Speed/Torque Curve

GE Type: KR
 Starting Current: Low
 Starting Torque: Very High
 Breakdown Torque: Not Applicable
 Full-Load Slip: High (5-8%; 8-13%)
 Applications: The combination of high starting torque and high slip make Type KR motors ideal for very high inertia loads and/or for considerable variations in load; e.g., punch presses, shears, cranes, hoists and elevators.

The following tables compare NEMA polyphase designs for several performance criteria.

Table 5. Comparison of Polyphase Designs

NEMA Design	Starting Current	Locked-Rotor Torque	Breakdown Torque	% Slip	Applications
A	High to Medium	Normal	Normal	Max 5%	Broad applications including fans, blowers, pumps, machined tools.
B	Low	Normal	Normal	Max 5%	Normal starting torque for fans, blowers, rotary pumps, unloaded compressors, some conveyors, metal cutting machine tools, misc. machinery. Constant load speed.
C	Low	High	Normal	Max 5%	High inertia starts such as large centrifugal blowers, fly wheels and crusher drums. Loaded starts such as piston pumps, compressors and conveyors. Constant load speed.
D	Low	Very High	–	–	Very high inertia and loaded starts. Choice of slip to match load.
				5-8%	1) Punch presses, shears and forming machine tools
				8-13%	2) Cranes, hoists, elevators and oil well pumping jacks.

LOCKED-ROTOR TORQUE

Table 6. Minimum Locked-rotor Torque - NEMA MG1, Part 12 (% of Full-load Torque)

Hp	Design A and B							Design C			Design D		
	3600 rpm @ 60 Hz	1800 rpm @ 60 Hz	1200 rpm @ 60 Hz	900 rpm @ 60 Hz	720 rpm @ 60 Hz	600 rpm @ 60 Hz	514 rpm @ 60 Hz	1800 rpm @ 50 Hz	1200 rpm @ 50 Hz	900 rpm @ 50 Hz	1800 rpm @ 50 Hz	1200 rpm @ 50 Hz	900 rpm @ 50 Hz
1	–	275	170	135	135	115	110	–	–	–	275	275	275
1.5	175	250	165	130	130	115	110	–	–	–	275	275	275
2	170	235	160	130	125	115	110	–	–	–	275	275	275
3	160	215	155	130	125	115	110	–	250	225	275	275	275
5	150	185	150	130	125	115	110	250	250	225	275	275	275
7.5	140	175	150	125	120	115	110	250	225	200	275	275	275
10	135	165	150	125	120	115	110	250	225	200	275	275	275
15	130	160	140	125	120	115	110	225	200	200	275	275	275
20	130	150	135	125	120	115	110	200	200	200	275	275	275
25	130	150	135	125	120	115	110	200	200	200	275	275	275
30	130	150	135	125	120	115	110	200	200	200	275	275	275
40	125	140	135	125	120	115	110	200	200	200	275	275	275
50	120	140	135	125	120	115	110	200	200	200	275	275	275
60	120	140	135	125	120	115	110	200	200	200	275	275	275
75	105	140	135	125	120	115	110	200	200	200	275	275	275
100	105	125	125	125	120	115	110	200	200	200	275	275	275
125	100	110	125	120	115	115	110	200	200	200	275	275	275
150	100	110	120	120	115	115	–	200	200	200	275	275	275
200	100	100	120	120	115	–	–	200	200	200	–	–	–
250	70	80	100	100	–	–	–	–	–	–	–	–	–
300-350	70	80	100	–	–	–	–	–	–	–	–	–	–
400-500	70	80	–	–	–	–	–	–	–	–	–	–	–

PULL-UP TORQUE

The pull-up torque for NEMA design A and B motors listed in Table 6 with rated voltage and frequency applied will not be less than the following:

Table 7. Minimum Pull-up Torque - NEMA MG1, Part 12

Design A and B Locked-rotor torque from Table 6.	Pull-up Torque
110 percent or less	90 percent of locked-rotor torque in Table 6.
Greater than 110 percent but less than 145 percent	100 percent of full-load torque in Table 6.
145 percent or more	70 percent of locked-rotor torque in Table 6.

The pull-up torque of Design C motors, with rated frequency and voltage applied, will not be less than 70 percent of the locked-rotor torque in Table 6.

BREAKDOWN TORQUE

Table 8. Minimum Breakdown Torque - NEMA MG1, Part 12 (% of Full-Load Torque)

Hp rpm @ 60 Hz rpm @ 50 Hz	Design A and B							Design C		
		3600	1800	1200	900	720	600	514	1800	1200
	3000	1500	1000	750	—	—	—	1500	1000	750
1	—	300	265	215	200	200	200	—	—	—
1.5	250	280	250	210	200	200	200	—	—	—
2	240	270	240	210	200	200	200	—	—	—
3	230	250	230	205	200	200	200	—	225	200
5	215	225	215	205	200	200	200	200	200	200
7.5	200	215	205	200	200	200	200	190	190	190
10	200	200	200	200	200	200	200	190	190	190
15	200	200	200	200	200	200	200	190	190	190
20	200	200	200	200	200	200	200	190	190	190
25	200	200	200	200	200	200	200	190	190	190
30	200	200	200	200	200	200	200	190	190	190
40	200	200	200	200	200	200	200	190	190	190
50	200	200	200	200	200	200	200	190	190	190
60	200	200	200	200	200	200	200	190	190	190
75	200	200	200	200	200	200	200	190	190	190
100	200	200	200	200	200	200	200	190	190	190
125	200	200	200	200	200	200	200	190	190	190
150	200	200	200	200	200	200	—	190	190	190
200	200	200	200	200	200	—	—	190	190	190
250	175	175	175	175	—	—	—	—	—	—
300	175	175	175	—	—	—	—	—	—	—
350	175	175	175	—	—	—	—	—	—	—
400	175	175	—	—	—	—	—	—	—	—
450	175	175	—	—	—	—	—	—	—	—
500	175	175	—	—	—	—	—	—	—	—

POLYPHASE MOTORS LARGER THAN 500 HP

Ratings larger than those listed in Tables 6, 7 and 8 are not covered by NEMA design letters, but have minimum torques established by NEMA MG1 as follows:

Table 9. Motor Torque - NEMA MG1, Part 20

Torque	*Minimum Percentage of Rated Full-Load Torque
Locked-Rotor	60
Pull-up	60
Breakdown	175

* Higher values can be quoted for specific applications.

Locked-rotor current of these designs will normally not exceed 650% of full-load current, and will normally be within NEMA locked-rotor KVA limits for a code G or H motor.

SINGLE-PHASE MOTORS

NEMA DESIGN L

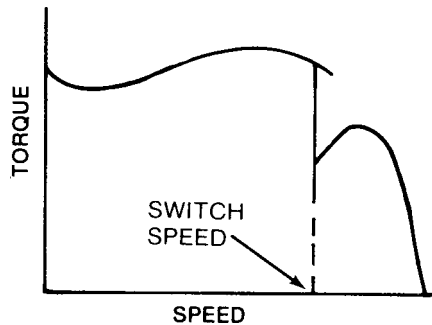

Figure 13. Typical NEMA Design L Speed/Torque Curve

A NEMA design L motor is a single-phase integral horsepower motor designed to withstand full-voltage starting. The GE offering to meet design limits of design L is a type KC. Starting performance of type KC motors is dependent upon a “start” winding controlled by a centrifugal mechanism and switch. Upon energization of the motor, both the “start” winding and the “run” winding of the motor are connected to the line. As the motor comes up to speed, the centrifugal mechanism will actuate and open the switch, removing the start provisions from the line. The rpm at which this occurs is known as “switch speed”. The motor will then operate at full-load with only the run windings connected.

Breakdown torques developed by Design L motors are shown in the following table:

Table 10. Single-phase (Design L) Breakdown Torque in lb-ft (NEMA MG1, Part 10)

Hp	Frequency (hertz)					
	60		50		60	
	Synchronous Speed					
	3600	3000	1800	1500	1200	1000
1	—	—	5.16-6.8	6.19-8.2	6.9-9.2	*
1.5	3.6-4.6	4.3-5.5	6.8-10.1	8.2-12.1	9.2-13.8	*
2	4.6-6.0	5.5-7.2	10.1-13.0	12.1-15.6	13.8-18.0	*
3	6.0-8.6	7.2-10.2	13.0-19.0	15.6-22.8	18.0-25.8	*
5	8.6-13.5	10.2-16.2	19.0-30.0	22.8-36.0	25.8-40.5	*
7.5	13.5-20.0	16.2-24.0	30.0-45.0	36.0-54.0	40.5-60.0	*
10	20.0-27.0	24.0-32.4	45.0-60.0	54.0-72.0	*	*

* No torque values have been established for these ratings.

Maximum locked-rotor currents for Design L, 60 Hz motors are shown in the following table:

Table 11. Single-phase Maximum Locked-Rotor Current in Amperes at 230 Volts - NEMA MG1, Part 12

Hp	AMPS
1	45
1.5	50
2	65
3	90
5	135
7.5	200
10	260

SERVICE FACTOR

Service factor is defined as the permissible amount of overload a motor will handle within defined temperature limits. When voltage and frequency are maintained at nameplate rated values, the motor may be overloaded up to the horsepower obtained by multiplying the rated horsepower by the service factor shown on the nameplate. However, locked-rotor torque, locked-rotor current and breakdown torque are unchanged. NEMA has defined service factor values for standard polyphase dripproof, 60 Hz motors as shown in the following table:

Table 12. Service Factor

Hp	Synchronous Speed, rpm						
	3600	1800	1200	900	720	600	514
1	1.25	1.15*	1.15*	1.15*	1.0	1.0	1.0
1.5 - 125	1.15*	1.15*	1.15*	1.15*	1.15*	1.15*	1.15*
150	1.15*	1.15*	1.15*	1.15*	1.15*	1.15*	1.0
200	1.15*	1.15*	1.15*	1.15*	1.15*	1.0	1.0
Over 200	1.0	1.0	1.0	1.0	1.0	1.0	1.0

* These service factors apply only to NEMA design A, B and C motors.

MOTOR TEMPERATURE

A major consideration in both motor design and application is heat. Excessive heat will accelerate motor insulation deterioration and cause premature insulation failure. Excessive heat may also cause a breakdown of bearing grease, thus damaging the bearing system of a motor.

The total temperature a motor must withstand is the result of two factors: external, or ambient temperature; and internal, or motor temperature rise. An understanding of how these components are measured and expressed is important for proper motor application.

For a given application, the maximum sustained ambient temperature, measured in degrees Celsius, should be determined. Most motors are designed to operate in a maximum ambient temperature of 40°C. If the ambient temperature exceeds 40°C, the motor may need to be modified to compensate for the increase in total temperature.

The temperature rise is the result of heat generated by motor losses during operation. At no-load, friction in the bearings, core losses (eddy current and hysteresis losses), and stator I²R losses contribute to temperature rise; at full-load, additional losses which cause heating are rotor I²R losses and stray load losses. (NOTE: I = current in amps and R = resistance of the stator or rotor in ohms).

Since current increases with an increase in motor load and under locked-rotor, temperature rise will be significantly higher under these conditions. Therefore, applications requiring frequent starting and/or frequent overloads may require special motors to compensate for the increase in total temperature.

MOTOR COOLING

Since the total temperature of a motor is greater than the surrounding environment, heat generated during motor operation will be transferred to the ambient air. The rate of heat transfer affects the maximum load and/or the duty cycle of a specific motor design. Factors affecting this rate of transfer are:

1. Motor enclosure

Different enclosures result in different airflow patterns which alter the amount of ambient air in contact with the motor.

2. Frame surface area

Increasing the area of a motor enclosure in contact with the ambient air will increase the rate of heat transfer. General Electric motor enclosures often are cast with many ribs to increase their surface area for cooler operation.

3. Airflow over motor

The velocity of air moving over the enclosure affects the rate of heat transfer. Fans are provided on most totally-enclosed and some open motors to increase the velocity of air over the external parts.

4. Ambient air density

A reduction in the ambient air density will result in a reduction of the rate of heat transfer from the motor. Therefore, total operating temperature increases with altitude. Standard motors are suitable for operation up to 3300 feet; motors with service factor may be used at altitudes up to 9900 feet at 1.0 service factor.

INSULATION CLASS VS TEMPERATURE

NEMA has classified insulation systems by their ability to provide suitable thermal endurance. The total temperature is the sum of ambient temperature plus the motor's temperature rise. The following charts illustrate the maximum total motor temperature allowed for each of the standard classes of insulation. An additional 10 degrees C measured temperature rise is permitted when temperatures are measured by detectors embedded in the winding. Figures 15-17 illustrate the temperature rise limits established for various insulation classes per NEMA MG1, Part 12.

ENCLOSURE: DRIPPROOF OR TEFC, SERVICE FACTOR: 1.0 INSULATION CLASS

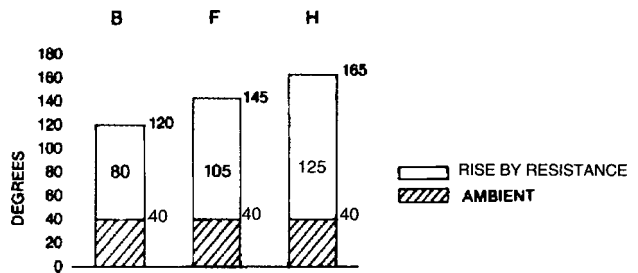

Figure 15.

ENCLOSURE: TENV, SERVICE FACTOR: 1.0 INSULATION CLASS

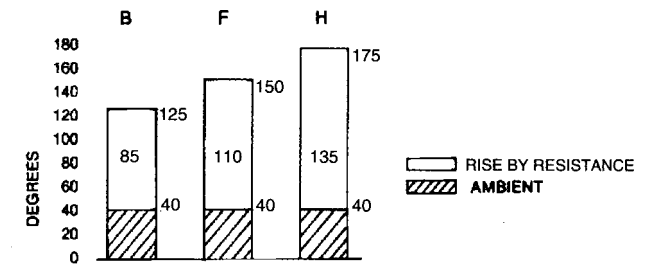

Figure 16.

ENCLOSURE: DRIPPROOF OR TEFC, SERVICE FACTOR: 1.15 INSULATION CLASS

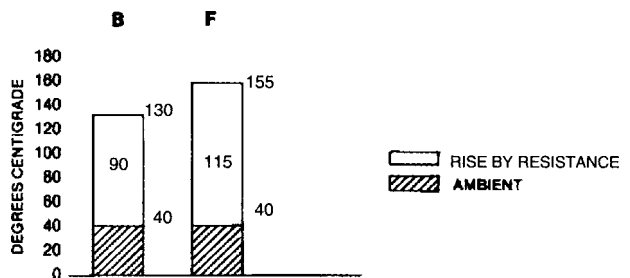

Figure 17.

DUTY CYCLE APPLICATIONS

TYPES OF DUTY

The duty cycle of a motor describes the energization/deenergization, and load variations, with respect to time for any given application. Duty cycle applications may be divided into three basic classifications:

1. Continuous duty is a requirement of service that demands operation at an essentially constant load for an indefinitely long time. This is the most common duty classification and accounts for approximately 90% of motor applications. To size a motor for a specific application with this duty cycle classification, select proper horsepower based upon continuous load.
2. Intermittent duty is a requirement of service that demands operation for alternate intervals of load and no-load; or load and rest; or load, no-load and rest; each interval of which is definitely specified. Select a motor for these applications to match the horsepower requirements under the loaded condition. In some instances, such as a hoist or elevator application, savings in the purchase price of a motor may be possible by designing for the intermittent duty cycle. 30 or 60 minute motors are normally specified. Frequent starts, however, can increase motor heating.
3. Varying duty is a requirement of service that demands operation at loads and for intervals of time, which may be subject to wide variation. For this classification of duty cycle, a horsepower versus time curve will permit determination of the peak horsepower required and a calculation of the root-mean-square (RMS) horsepower will indicate the proper motor rating from a heating standpoint. The following example demonstrates the method for selecting a motor for a varying duty cycle based upon peak horsepower and RMS horsepower requirements assuming constant frequency.

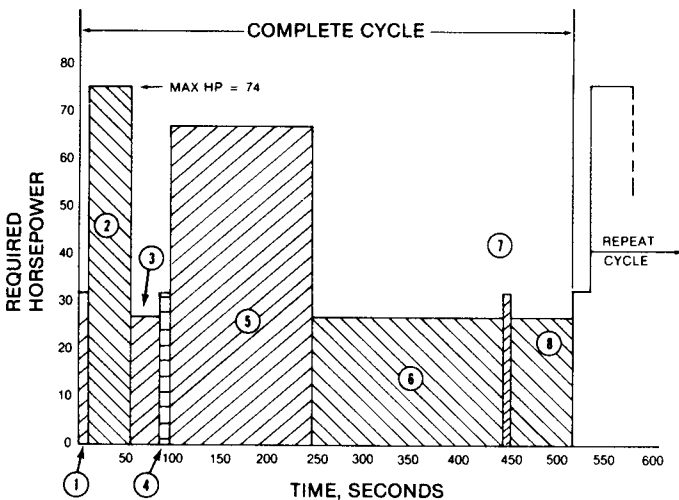

Figure 18. Duty Cycle Calculation

To properly size a motor for the varying duty cycle described in the preceding horsepower versus time graph, a table should be made as shown quantifying each part of the cycle. The first three columns of this table list data from the graph, and the fourth column is derived by squaring the horsepower and multiplying by the time for each part of the cycle. Using this data, sum the periods of time and (Hp)²t, and evolve the RMS horsepower as follows:

Table 12.

Part of Cycle	Time Sec. (t)	Required Hp	(Hp) ² t
1	15	32	15,360
2	40	74	219,040
3	30	27	21,870
4	5	32	5,120
5	148	66	644,690
6	200	27	145,800
7	12	32	12,290
8	70	27	51,030
	520		1,115,200

$$\text{RMS Hp} = \sqrt{\frac{\sum (\text{Hp})^2 t}{\sum t}}$$

RMS Hp = Root-Mean-Square Horsepower

$$\text{RMS Hp} = \sqrt{\frac{1,115,200}{520}} = \sqrt{2145} = 46.3 \text{ Hp}$$

The load RMS horsepower is used to determine the required motor thermal capability at constant speed. To allow for ±10% voltage variation and the resulting additional motor heating, particularly at peak loads and 90% voltage, a 10% allowance is added to the RMS horsepower calculation:

$$\begin{aligned} \text{Required Hp} &= \text{RMS Hp} \times 1.10 \\ &= 46.3 \times 1.10 = 50.9 \text{ Hp} \end{aligned}$$

The motor usable horsepower is determined by the nameplate Hp x service factor and must be equal to or greater than the required horsepower. In our example, there is a choice of either a 50 Hp motor with a 1.15 service factor or a 60 Hp motor at a 1.0 service factor. From a thermal viewpoint, either of these ratings are suitable for the required load Hp of 50.9.

The motor must also be capable of carrying the peak horsepower (torque) value from the duty cycle at 90% voltage. Since motor breakdown torque is reduced by the voltage squared, the required breakdown torque (BDT) is determined by the equation:

$$\begin{aligned} \%BDT &= \left[\frac{\text{Peak-Load Hp} \times 100}{\text{NP Hp} \times .9^2} \right] + 20 \text{ (see note)} \\ &= \left[\frac{\text{Peak-Load Hp} \times 123}{\text{NP Hp}} \right] + 20 \end{aligned}$$

NP Hp = Nameplate Rated Horsepower

%BDT = Percent Breakdown Torque

NOTE: Margin of 20% added to prevent inefficiencies of operation too close to actual breakdown torque.

For example, with a 50 Hp motor at 1.15 SF:

$$\%BDT = [74/50 \times 123 + 20] = 202\%$$

For 60 Hp at 1.0 SF:

$$\%BDT = [74/60 \times 123 + 20] = 172\%$$

Conclusion: Since the NEMA breakdown torque for a 50 Hp or 60 Hp motor is 200%, the best choice for the application is the 60 Hp rating which only requires 172% at the peak-load horsepower.

STARTING LOAD INERTIA (WK²)

In any type of duty cycle operation, it is necessary to determine not only the horsepower requirements but the number of times the motor will be started, the inertia of the driven machine, the type of load (constant or variable torque) and the method of stopping the motor.

The inertia (WK²) of the rotating parts of the driven equipment affects the acceleration time and motor heating during acceleration. The heating of motor rotor and stator during frequent starting, stopping, and/or reversals can become a design limitation.

If the motor is direct connected, the inertia supplied by the equipment manufacturer may be used as is. If the motor is to drive the equipment through a pulley or gear such that the driven equipment is operating at a higher or lower speed than the motor, it is necessary to calculate the inertia "referred to the motor shaft"; that is, an equivalent inertia based on the speed of the motor.

WK² (Referred to Motor Shaft) =

$$WK^2 \text{ (Driven Equipment)} \times \frac{\text{RPM}^2 \text{ (Driven Equipment)}}{\text{RPM}^2 \text{ (Motor)}}$$

The method of stopping the motor is also taken into consideration in a duty cycle calculation. For example, if the motor is allowed to coast to a stop or mechanical braking is used, the RMS horsepower calculation may be affected. Plug stopping or DC braking increases motor heating considerably. Therefore, the method of stopping must be part of the duty cycle data provided.

STARTING FREQUENCY

A special kind of duty cycle is one in which a motor is required to perform repetitive starts with a given load and connected inertia. Motor selection must take into account the motor heating caused by starting frequency, load inertia and running load.

A motor during acceleration draws about 6 times full-load current, so resistance losses during starting are up to 36 times (current squared) the losses at full-load. A motor operating on a low inertia load (pump) may come up to speed very quickly, in less than one second. Starting losses may be so low that the start cycle could be repeated several times per minute without overheating the winding. However, motor life can be limited by mechanical starting stresses. When frequent starting is planned refer to NEMA MG10.

HIGH INERTIA LOADS

At the other extreme, the same motor connected to a high inertia load (centrifuge) could burn out before getting up to full speed on the first start. Motor applications involving frequent starts or high load inertia must be carefully studied to obtain satisfactory operation and long motor life.

The following table lists recommended maximum load inertias for type K, KG, KS and KGS, 60 or 50 Hz, motors starting a fan or centrifugal pump load for two successive cold starts or one start from rated load temperature. The cold starts should be possible within 10 seconds of each other at rated frequency and voltage, and permitted by conventional control. It is recommended, however, that high inertia drives have thermal protection in the motor to prevent burnout from misapplication or excessive starting frequency.

**Table 13. Maximum Load Inertia
NEMA MG1, Parts 12 and 20**

Hp	Speed, RPM						
	3600	1800	1200	900	720	600	514
	Load WK ² (Exclusive of Motor WK ²) lb-ft ²						
1	—	5.8	15	31	53	82	118
1.5	1.8	8.6	23	45	77	120	174
2	2.4	11	30	60	102	158	228
3	3.5	17	44	87	149	231	335
5	5.7	27	71	142	242	375	544
7.5	8.3	39	104	208	356	551	798
10	11	51	137	273	467	723	1048
15	16	75	200	400	685	1061	1538
20	21	99	262	525	898	1393	2018
25	26	122	324	647	1108	1719	2491
30	31	144	384	769	1316	2042	2959
40	40	189	503	1007	1725	2677	3881
50	49	232	620	1241	2127	3302	4788
60	58	275	735	1473	2524	3819	5680
75	71	338	904	1814	3111	4831	7010
100	92	441	1181	2372	4070	6320	9180
125	113	542	1452	2919	5010	7790	11310
150	133	640	1719	3456	5940	9230	—
200	172	831	2238	4508	7750	12060	—
250	210	1017	2744	5540	9530	14830	—
300	246	1197	3239	6540	11270	—	—
350	281	1373	3723	7530	—	—	—
400	315	1546	4199	8500	—	—	—
450	349	1714	4666	9460	—	—	—
500	381	1880	5130	—	—	—	—
600	443	2202	6030	—	—	—	—
700	503	2514	—	—	—	—	—
800	560	2815	—	—	—	—	—

EFFICIENCY

DEFINITION

Efficiency is an important application consideration. That is especially true for applications having high hours of operation where cost of motor operation is many times the initial purchase price of the motor.

As shown below, efficiency is defined as watts output over watts input using 746 watts as the equivalent of one horsepower:

$$\text{Efficiency} = \frac{746 \times \text{Hp Output}}{\text{Watts Input}} = \frac{\text{Watts Output}}{\text{Watts Input}}$$

This can also be expressed as the watts input minus the losses divided by the watts input.

$$\text{Efficiency} = \frac{\text{Input} - \text{Losses}}{\text{Input}}$$

The only way to improve efficiency is to reduce losses. Although input power is readily measured, power out is difficult to measure accurately. Therefore, precision equipment is required to determine the efficiency and the losses in a motor. Standard test procedures are defined to measure the individual components of loss separately in order to improve the accuracy of efficiency determination.

DESCRIPTION OF MOTOR LOSSES

Typically, motor losses are categorized, first, as those which occur while the motor is energized but operating at no-load; and, second, those additional losses due to the output load. Specific losses are:

1. **No-load losses**
 - a. Windage and friction
 - b. Stator iron losses
 - c. Stator I²R losses
2. **Load Losses**
 - a. Stator I²R losses (due to increase in current under load)
 - b. Rotor I²R
 - c. Stray load losses

The no-load losses and the conductor losses under load can be measured separately, however, the stray load loss requires accurate input-output test equipment for determination. The stray-load loss consists of losses due to harmonic currents and flux in the motor. Factors affecting stray load losses include:

- Stator and rotor slot geometry
- Number of slots
- Air gap length
- Rotor slot insulation
- Manufacturing process

MOTOR TESTING

Good motor application practice requires that uniform and meaningful terminology be used to define efficiency values which are determined by accurate test procedures uniformly applied by the motor manufacturers.

Testing to accurately determine the value of motor losses can be time consuming and expensive. Also, wide variations in results can be experienced when different test methods are used. In order to maintain consistency, NEMA has established the following guidelines:

Efficiency and losses shall be determined in accordance with the latest revision of IEEE standard 112. Polyphase squirrel-cage motors rated 1-125 Hp shall be tested by dynamometer, Method B. The efficiency will be determined using segregated losses in which stray load loss is obtained from a linear regression analysis to reduce the effect of random errors in the test measurements.

This procedure focuses on stray load losses where the greatest variance can occur from one motor to the next. It also clearly defines the procedure and requires testing either at full operating temperature or by making corrections for temperature differences. Finally, test method B requires use of a dynamometer to provide the most accurate data as a basis for accuracy improvement and stray load loss measurement.

Motor efficiency is not an absolute or constant for all motors of the same design. Rather, the efficiencies of a large number of motors will fit a normal distribution or "bell" curve as shown in Figure 19.

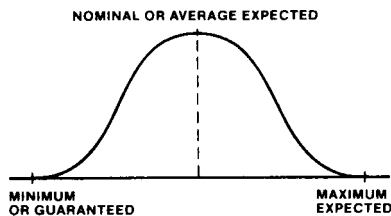

Figure 19. Efficiency Distribution

The nominal efficiency which appears on the motor nameplate corresponds to the nominal, or average expected efficiency on the curve. The guaranteed minimum efficiency appearing on GE energy efficient motor nameplates corresponds to the minimum, or guaranteed on the curve.

POWER FACTOR

In a sense, motors are electromagnets and power factor is a measure of the amount of magnetizing current required.

Power factor is an important consideration when selecting a motor for a particular application since low power factor may result in power factor penalty charges from the utility company. Since the power company must supply KVA but normally meters only kilowatts used, low motor power factor requires additional KVA with low return on KW utilized; hence, power factor penalties.

Following is the equation for power factor in a three-phase system:

$$PF = \frac{\text{Watts Input}}{\sqrt{3} \times \text{Volts} \times \text{Amps}}$$

This equation is a numerical method of expressing the phase difference between voltage and current in a motor circuit. The current in an induction motor lags the applied voltage, and only the component that is in phase with the voltage varies with motor power. The relationship expressed in the above equation can be shown as a vector relationship in which the numerical expression is actually the cosine of the angle L.

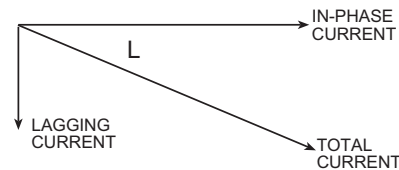

$$\text{Amps} = \frac{\text{Watts Input}}{\sqrt{3} \times \text{Volts} \times PF}$$

Figure 20.

As seen from their relationship, line current required for a given motor output varies inversely with power factor. Increasing power factor will reduce required line current, thus reducing voltage drop in power lines and transformers.

The lagging current shown above is actually motor magnetizing current, which is dependent upon motor design. This magnetizing current is independent of motor load; i.e., just as much is required at no-load as at full-load. Thus power factor at partial loads is never as high as at full-load, and at no-load power factor is essentially zero.

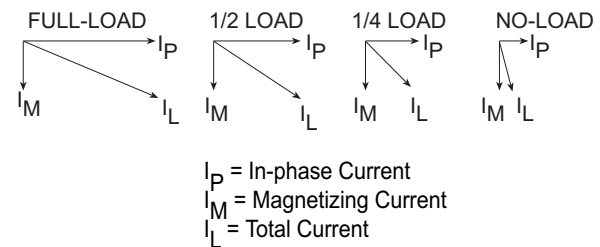

Figure 21.

There are two basic methods for improving the power factor of a motor for a particular application:

1. Purchase a motor with an inherently high power factor.
2. Install power factor correction capacitors. Capacitors draw leading current as opposed to the lagging current drawn by induction motors. Placing capacitors in parallel with the motor windings will result in leading current offsetting some of the lagging current, increasing power factor as shown in Figure 22:

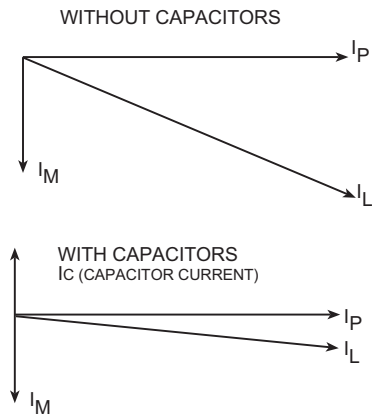

Figure 22. Power Factor Correction

For many applications the use of capacitors for power factor correction is the most economical method and one that also works at partial loads. Capacitors should be used to improve full-load power factor to approximately 95% maximum.

WARNING: IN NO CASE SHOULD POWER FACTOR IMPROVEMENT CAPACITORS BE APPLIED IN RATINGS EXCEEDING THE MAXIMUM SAFE VALUE SPECIFIED BY THE MOTOR MANUFACTURER. EXCESSIVE IMPROVEMENT MAY CAUSE OVER EXCITATION RESULTING IN HIGH TRANSIENT VOLTAGES, CURRENTS AND TORQUES THAT CAN INCREASE SAFETY HAZARDS TO PERSONNEL AND CAUSE POSSIBLE DAMAGE TO THE MOTOR OR TO THE DRIVEN EQUIPMENT.

LOAD CONNECTION

TYPES OF CONNECTION

Two methods of mechanical connection of the motor to the driven load are commonly used:

1. Direct Connection

Direct connection should always be considered where the required load speed coincides with an available motor speed. The preferred practice is to use a flexible coupling which will allow a slight amount of misalignment and minimize transmission of thrust to the motor bearings. Axial thrust loads are commonly encountered when a pump impeller or fan is mounted on the motor shaft. They also occur in direct connected helical gear drives and when the motor is mounted vertically or in an inclined position where any weight other than the rotor is supported by the motor shaft. Refer to Table 14 for recommended maximum axial thrust loads for horizontal ball-bearing motors with typical bearing sizes.

2. Belt, chain and gear drives

When connecting a motor to its load with this type of drive, proper selection is necessary to limit bearing loads within radial load capacities. Table 15 and 15A provide recommended minimum V-belt sheave diameters for 60 and 50 Hz motors. Table 15 and 15A indicate the approximate radial forces corresponding to a belt tightened sufficiently to prevent slippage. Additional tension will increase the radial force and decrease bearing life. For A-B-C-D-E belts, the center line of the pulley should not extend beyond the end of the shaft. For 3V-5V-8V belts, the centerline of the pulley should not be any closer to the end of the shaft than 1/2 the V dimension of the shaft.

Table 14. Axial Thrust (pounds) for Horizontal Motors

Frame	3600 RPM		1800 RPM		1200 RPM		900 RPM	
	Brg	Thrust	Brg	Thrust	Brg	Thrust	Brg	Thrust
182-184	6206	140	6206	165	6206	220	6206	245
213-215	6307	250	6307	335	6307	375	6307	425
254-256	6309	405	6309	500	6309	670	6309	710
284-286	6310	460	6310	625	6310	770	6310	790
324-326	6210	230	6210	290	6210	395	6210	325
364-365	6213	390	6213	485	6213	630	6213	635
404-405	6313	375	6213	435	6213	590	6213	710
444-445	6314	760	6314	1040	6314	1205	6314	1400
449	6314	705	6314	965	6314	1115	6314	1325
509	6315	705	6318	1175	6318	1275	6318	1445
511	6315	680	6318	1030	6318	1290	6318	1260
513	6315	620	6320	1265	6320	1360	6320	1450

NOTE: Table 14 assumes no external radial loading on the shaft.

Thrust values in Table 14 represent the maximum permissible to provide a 25,000 hour L_{10} life in accordance with AFBMA calculations.

Table 15. Limiting Sheave Dimensions for V-Belt Drive (Frames 182T - 449T)

Frame	Horsepower at Sync. Speed, RPM				V-Belt Sheave (inches)*				
					Conventional		Narrow		
					A, B, C, D and E Sections		3V, 5V and 8V Sections		
60 Hz	3600	1800	1200	900	Min Pitch Dia.	Max Width	Min Outside Dia.	Max Width	Belt Pull (lbs.)**
182T	3	3	1.5	1	2.4	5.25	2.4	2.75	155
182T	5	-	-	-	2.6	5.25	2.4	2.75	130
184T	-	-	2	1.5	2.4	5.25	2.4	2.75	155
184T	5	-	-	-	2.6	5.25	2.4	2.75	130
184T	7.5	5	-	-	3.0	5.25	3.0	2.75	210
213T	7.5-10	7.5	3	2	3.0	6.5	3.0	3.38	310
215T	10	-	5	3	3.0	6.5	3.0	3.38	310
215T	15	10	-	-	3.8	6.5	3.8	3.38	355
254T	15	-	7.5	5	3.8	7.75	3.8	4.0	370
254T	20	15	-	-	4.4	7.75	4.4	4.0	425
256T	20-25	-	10	7.5	4.4	7.75	4.4	4.0	425
256T	-	20	-	-	4.6	7.75	4.4	4.0	565
284T	30	-	-	-	4.4	9.0	4.4	4.58	425
284T	-	-	15	10	4.6	9.0	4.4	4.58	625
284T	-	25	-	-	5.0	9.0	4.4	4.58	705
286T	30	-	-	-	4.4	9.0	4.4	4.58	425
286T	40	-	-	-	4.6	9.0	4.6	4.58	540
286T	-	30	20	15	5.4	9.0	5.2	4.58	715
324T	40	-	-	-	4.6	10.25	4.6	5.25	540
324T	-	40	25	20	6.0	10.25	6.0	5.25	825
324T	50	-	-	-	5.0	10.25	5.0	5.25	620
326T	50	-	-	-	5.0	10.25	5.0	5.25	620
326T	-	50	30	25	6.8	10.25	6.8	5.25	910
326T	60	-	-	-	5.4	10.25	5.4	5.25	690
364T	-	-	40	30	6.8	11.5	6.8	5.88	1095
364T	60	-	-	-	5.4	11.5	5.4	5.88	690
364T	-	60	-	-	7.4	11.5	7.4	5.88	1005
365T	-	-	50	40	8.2	11.5	8.2	5.88	1210
365T	-	75	-	-	9.0	11.5	8.6	5.88	1080
404T	-	-	60	-	9.0	14.25	8.0	7.25	1395
404T	-	-	-	50	9.0	14.5	8.4	7.25	1475
404T	-	100	-	-	10.0	14.25	8.6	7.25	1440
405T	-	-	75	60	10.0	14.25	10.0	7.25	1485
405T	-	100	-	-	10.0	14.25	8.6	7.25	1440
405T	-	125	-	-	11.5	14.25	10.5	7.25	1475
444T	-	-	100	-	11.0	16.75	10.0	8.5	1770
444T	-	-	-	75	10.5	16.75	9.5	8.5	1955
444T	-	125	-	-	11.0	16.75	9.5	8.5	1630
444T	-	150	-	-	-	-	10.5	8.5	1770
445T	-	-	125	-	12.5	16.75	12.0	8.5	1935
445T	-	-	-	100	12.5	16.75	12.0	8.5	2065
445T	-	150	-	-	-	-	10.5	8.5	1770
445T	-	200	-	-	-	-	13.2	8.5	1875
445T	-	-	150	-	-	-	13.5	8.5	2065
449T	-	-	200	-	-	-	18.75	8.5	1980
449T	-	-	-	150	-	-	19.0	8.5	1955
449T	-	-	-	200	-	-	27.75	8.5	1785
449T	-	250	-	-	-	-	15.5	12.75	1995

* Applicable to motors with long T shaft only.

** Force for highest torque rating.

NOTE: The recommended sheave diameters are based on a 5:1 speed reduction, and a pulley center-to-center distance approximately equal to the diameter of the larger sheave. Shaft extension is the minimum required by NEMA (Table MG1 11.31)

Sheave diameter is minimum required by NEMA (Table 14-1) for narrow V-belt sections.

**Table 15A. Limiting Sheave Dimensions for V-Belt Drive
Typical 500 Frame Data**

Dripproof			Brg. Const.	Min. Sheave Dia. (in.)	Belt Pull (lbs.)
Horsepower @ RPM					
1800	1200	900			
–	–	150	(1)	16.5	2200
–	–	200	(2)	9	5500
–	–	250	(2)	17	3600
–	250	–	(2)	9	5200
–	300	–	(2)	15	3700
300	–	–	(2)	7.5	4900
350	–	–	(2)	13.5	3200
TEFC Motors					
–	–	125	(1)	14.5	2100
–	–	150	(1)	18	2100
–	–	200	(2)	13	3800
–	200	–	(1)	18	2100
–	250	–	(2)	15	3100
–	250*	–	(2)	10.5	4400
250	–	–	(1)	17.5	1800
300	–	–	(2)	9	4100
350	–	–	(2)	11.5	3800

* for 5011L frame size.

(1) Deep groove ball-bearing construction

(2) Special shaft materials and roller-bearing construction.

- NOTE:**
1. Minimum bearing life, L10, for a given sheave diameter is 25,000 hours.
 2. The recommended sheave diameters are based on a 5:1 speed reduction and a sheave center-to-center distance approximately equal to the diameter of the larger sheave.

CAUTION: BELT SPEEDS IN EXCESS OF 6500 FEET PER MINUTE MAY REQUIRE SPECIAL SELECTION OF DRIVE COMPONENTS. MOTOR USER SHOULD GET SPECIFIC APPROVAL FROM BELT AND SHEAVE SUPPLIER FOR SUCH APPLICATIONS.

ELECTRICAL CONSTRUCTION

WINDING CONNECTIONS AND STARTING

The design of a motor's windings and the pattern of connecting the leads from these windings will determine voltage ratios for dual-voltage motors and may also determine what starting options are available.

Following is a brief description of some of the more popular starting methods:

1. Full Voltage Starting

This method is the least expensive from an initial cost standpoint and is the most commonly used starting method on smaller motors. While it results in the highest inrush current values, connections and starter operation are greatly simplified. All standard motors are designed for full voltage (across-the-line) starting.

2. Part Winding Starting (PWS)

This method energizes only part of the total winding when the motor is started and is suitable for pump, fan and compressor loads. PWS will reduce inrush current, but the motor heating rate will increase considerably. There are no standard performance requirements for part winding starting and, therefore, a motor started in this manner may fail to accelerate a high-inertia or constant torque load. PWS usually requires special winding connections which must be specified at the time the motor is ordered.

3. Autotransformer Starting

In contrast to part winding start, autotransformer starting uses the complete motor winding but limits input voltage to reduce inrush current. The most commonly furnished taps on autotransformer starters are 50, 65 and 80% of full voltage and most also provide an adjustable timer for switching to full voltage after the motor has accelerated. No special motor winding is required.

Table 16. Autotransformer Starter

% Full-Load Value			
Transformer Tap	Voltage & Current at Motor	Supply Line Current	Motor Output Torque
80% Tap	80	64*	64
65% Tap	65	42*	42
50% Tap	50	25*	25

* Autotransformer magnetizing current not included. Magnetizing current is usually less than 25 percent of motor full-load current.

4. Wye Start/Delta Run

This connection method allows a motor to be started at reduced load with reduced phase voltage and, therefore, with reduced inrush current. Wye Delta starters may be furnished with either open or closed transitions. Open transition, while generally lower in cost, will produce higher transient current than a closed transition starter at the transition from wye to delta.

MECHANICAL CONSTRUCTION

ENCLOSURE MATERIAL

Frame and endshield materials are listed below in Table 17.

Table 17.

Frame Size	Enclosure	Frame & Endshield Material
182-449	DP, TEFC, WPI	Aluminum-alloy, cast-iron or rolled steel
509-5013	DP, TEFC, WPI, WP11	Cast-iron
182-449	Severe-duty	Cast-iron
182-5013	Explosion-proof	Cast-iron
182-286	DP, TEFC, WPI	Rolled steel or cast iron
324-5013	DP, TEFC, WPI, WP11	Cast-iron
182-5013	Severe-duty	Cast-iron
182-5011	Explosion-proof	Cast-iron

DRAINS AND BREATHERS

Enclosed Motors (except explosion-proof)

Standard enclosed motor construction includes drain holes in the bottom of the motor. On X\$D severe-duty motors, special plugs designed to serve as both drains and breathers, are inserted into the drain holes. Available as an option is a sintered-metal breather and drain which acts as a one-way vent preventing entrance of contaminants while allowing the moisture to drain out.

Explosion-Proof

Standard explosion-proof motors are furnished without drains or breathers. Available as an option is the U.L. listed Crouse-Hinds breather/drain which acts as a one-way vent; preventing the entrance of contaminants while allowing moisture to drain out of the motor.

MOUNTING CONFIGURATIONS

The following diagram illustrates the various mounting possibilities for "horizontal" motors.

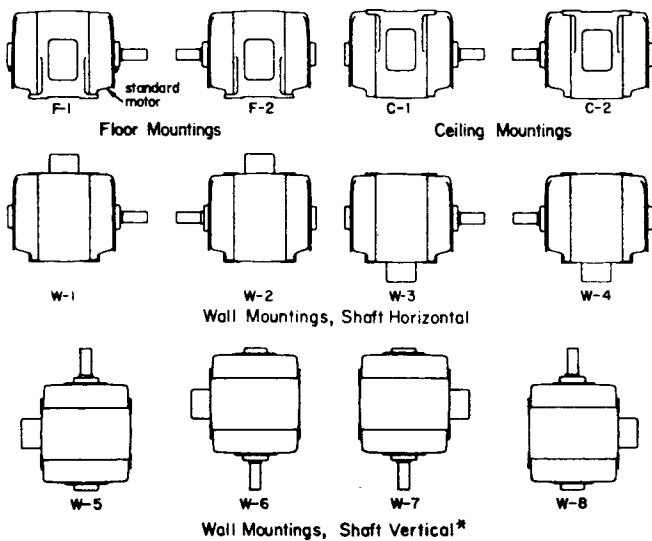

Figure 23.

Enclosed motors may be furnished for any of the twelve mounting configurations shown in Figure 23. 182-286 frame dripproof motors may be furnished for F1 and F2 mounting only. 324-449 frame dripproof motors may be furnished for any of the twelve mounting configurations.

Unless otherwise specified, all horizontal motors will be furnished for F1 mounting.

Vertical Mounting

Ball bearing motors in frames 326 and smaller mounted vertically with shaft up or down can handle external thrust loads, in either direction, not exceeding the thrust value shown in Table 14. Larger motors require a special lubrication system which can be furnished on request. Motors which are to be mounted vertically must be specified shaft up or down to obtain a suitable bearing and lubrication system.

DYNAMIC BALANCE

General Electric motors are dynamically balanced so that vibration, as tested per NEMA standard MG1-12.08, will be within the limits stated below for standard balance. Motors balanced to either the special or precision balance limits shown will be furnished at additional price when specified. Precision balance is a feature of the X\$D severe-duty product line.

Table 18. Vibration Limits (182-5013 Frame)

Motors with two ball bearings			
Vibration measured in Inches/Sec.			
RPM	Standard	Special	Precision
All speeds	0.15	0.075	0.055
Motors with one ball bearing and one roller bearing			
Vibration measured in Inches			
RPM	Standard	Special	Precision
3000-4000	0.0010	0.0005	0.0003
1500-2999	0.0015	0.0008	0.0004
1000-1499	0.0020	0.0010	0.0005
999 and slower	0.0025	0.0013	0.0007

BEARING SYSTEMS

Antifriction

All standard motors are equipped with "clean steel" Conrad deep-groove-type ball bearings, sized for the loads to be expected in industrial applications.

Sleeve-Type

Split-sleeve bearings are available for frames 509 through 5013 in dripproof and Weather Protected I and II enclosures. They should be used for direct drive applications only. These bearings are mounted in the bottom and top halves of the split endshields. The top half endshield is removable for bearing or winding inspection.

Solid sleeve bearings are available for frames 509 through 5013 totally-enclosed fan-cooled machines. Sleeve bearings are not available on explosion-proof motors.

All sleeve bearings are equipped with oil reservoirs, ring oilers, sight gauges, level gauges and drain provisions.

BEARING LUBRICATION

Ball bearing motors are shipped with sufficient grease for a long operating period. Relubrication at intervals consistent with the type of service shown in the following table will provide longer bearing life. Excessive or too frequent lubrication may damage the motor. Follow relubrication procedures provided in the instructions shipped with motors.

Table 19. Relubrication Intervals

Type of Service	Typical Examples	Hp Range	Relubrication Interval (yrs)	
			Horizontal	Vertical
Easy	Valves, door openers, portable floor sanders, motor operating infrequently (one hour per day)	1.0-7.5	10	9
		10-40	7	3
		50-150	4	1.5
		200-350	3	9 Mo.
Standard	Machine tools, air-conditioning apparatus, conveyors, one or two shifts, garage compressors, refrigeration machinery, laundry machinery, oil well pumps, water pumps, wood working machinery.	1.0-7.5	7	3
		10-40	4	1
		50-150	1.5	6 Mo.
		200-350	1	3 Mo.
Severe	Motor for fans, M-G sets, etc. that run 24 hours per day, 365 days per year, coal and mining machinery, motors subject to severe vibration, steel mill machinery.	1.0-7.5	4	1.5
		10-40	1.5	6 Mo.
		50-150	9 Mo.	3 Mo.
		200-350	6 Mo.	1.5 Mo.
Very Severe	Dirty, vibrating applications, where end of shaft is hot (pumps and fans), high ambient temperatures	1.0-7.5	9 Mo.	6 Mo.
		10-40	4 Mo.	3 Mo.
		50-150	4 Mo.	2 Mo.
		200-350	3 Mo.	1 Mo.
		400-800	2 Mo.	-

ENVIRONMENTAL CONSIDERATIONS

MOTOR ENCLOSURES

The type of enclosure required is dependent upon the surrounding atmosphere in which the motor is installed and the amount of mechanical protection and corrosion resistance required. The two general classes of motor enclosure are open and totally-enclosed. An open machine is one having ventilating openings which permit passage of external air over and around the winding of the motor. A totally-enclosed machine is constructed to prevent the free exchange of air between the inside and outside of the motor, but not sufficiently enclosed to be termed air-tight.

Derivatives of these two basic enclosures are described below:

Dripproof

Dripproof motors are designed to be internally ventilated by ambient air, having ventilation openings constructed so that successful operation is not affected when drops of liquid or solid particles strike the enclosure at any angle from 0 to 15 degrees downward from vertical. Dripproof motors are typically used in relatively clean, indoor applications.

Weather Protected Type I (WPI)

A weather protected type I machine is an open machine with its ventilating passages so constructed as to minimize the entrance of rain, snow and air-borne particles to the electric parts and having its ventilating openings so constructed as to prevent the passage of a cylindrical rod 3/4-inch in diameter.

Weather Protected Type II (WPII)

A weather protected type II machine shall have, in addition to the enclosure defined for a weather protected type I machine, ventilating passages at both intake and discharge so arranged that high-velocity air and airborne particles blown into the machine by storms or high winds can be discharged without entering the internal ventilating passages leading directly to the electric parts of the machine itself. For motors in frames 182T through 449T, standard TEFC motors should be specified. Ratings built in frames 509 and larger utilize dripproof frames with "top hat" mechanical construction to meet the above specifications. WPII motors have provisions for air filters.

Totally-Enclosed

Totally-enclosed motors are designed so that there is no free exchange of air between the inside and the outside of the enclosure, but not sufficiently enclosed to be airtight. Totally-enclosed motors may be of three basic types of construction.

1. TEFC (totally-enclosed fan-cooled) This type includes an external fan mounted on the motor shaft. This fan is enclosed in a fan casing which both protects the fan and directs the output air over the motor frame for cooling.
2. TEAO (totally-enclosed air-over) This type is similar to TEFC designs except that the cooling air being forced over the motor frame is provided by a fan which is not an integral part of the motor.
3. TENV (totally-enclosed non-ventilated) This type of construction does not require forced airflow over the motor frame for cooling.

Piped Ventilation

When motors are cooled by piping in outside air, the required airflow in cubic feet per minute (CFM) can be calculated from the equation:

$$CFM = \frac{Hp \left(\frac{100}{Eff\%} - 1 \right) (746 \times 1.8)}{10}$$

This results in a 10°C air temperature rise.

HAZARDOUS (CLASSIFIED) LOCATIONS

Specially designed totally-enclosed motors are available for operation in the classes of hazardous atmospheres, as defined by Underwriters Laboratories, the National Electrical Manufacturers Association and the National Electrical Code. Two basic classes are:

Class I Explosion-Proof

An explosion-proof motor is a totally-enclosed machine designed to withstand an explosion of a specified gas or vapor which may occur within it and to prevent the ignition of the specified gas or vapor surrounding the motor.

Class II Dust-Ignition Proof

A dust-ignition proof motor is a totally-enclosed machine constructed in a manner which will exclude ignitable amounts of dust or amounts which might affect performance or rating, and which will not permit arcs, sparks or heat generated inside the enclosure to cause ignition of exterior accumulations or atmospheric suspension of a specific dust and/or in the vicinity of the enclosure.

The various atmospheres defined within the two classes have been divided into groups dependent upon the explosive characteristics of the materials. The class and group of service shall appear on the motor nameplate along with an identification number which identifies a maximum operating temperature as shown in the following tabulations:

Table 20. Hazardous Atmospheres

Class	Group	ID No.	Atmosphere
I	A	T2A	Acetylene
I	B	T2A	Hydrogen, manufactured gas
I	C	T3C	Ethyl ether vapor
I	D	T2A	Gasoline, petroleum, naptha, alcohols,
		T2D*	acetone, lacquer solvents, natural gas
II	E	T3B	Metal dust
II	F	T3B	Carbon black, coal or coke dust
II	G	T3B	Grain dust

*T2A without thermostat/T2D with thermostat

Table 21. Temperature Identification Numbers

Maximum Temperature		Identification No.
Degrees C	Degrees F	
450	842	T1
300	572	T2
280	536	T2A
260	500	T2B
230	446	T2C
215	419	T2D
200	392	T3
180	356	T3A
165	329	T3B
160	320	T3C
135	275	T4
120	248	T4A
100	212	T5
85	185	T6

NOTE: For motors having multiple UL labels, the lowest identification number will apply.

Divisions, Hazardous Location

The National Electrical Code has defined two distinct divisions within each of the hazardous location classes:

- (a) Class I, Division 1 – A Class I, Division 1 location is a location: (1) in which ignitable concentrations of flammable gases or vapors exist under normal operating conditions, or (2) in which

ignitable concentrations of such gases or vapors may exist frequently because of repair or maintenance operations or because of leakage; or (3) in which breakdown or faulty operation of equipment or processes might release ignitable concentrations of flammable gases or vapors, and might also cause simultaneous failure of electric equipment. Division 1 locations always require the use of explosion-proof construction motors.

- (b) Class I, Division 2 – A Class I, Division 2 location is a location: (1) in which volatile flammable liquids or flammable gases are handled, processed, or used, but in which the liquids, vapors, or gases will normally be confined within closed containers or closed systems from which they can escape only in case of accidental rupture or breakdown of such containers or systems, or in case of abnormal operation of equipment; or (2) in which ignitable concentrations of gases or vapors are normally prevented by positive mechanical ventilation, and which might become hazardous through failure or abnormal operation of the ventilating equipment; or (3) that is adjacent to a Class I, Division 1 location, and to which ignitable concentrations of gases or vapors might occasionally be communicated. The National Electrical Code allows the installation of non-explosion-proof motors in Division 2 locations.
- (c) Class II, Division 1 – A Class II, Division 1 location is a location: (1) in which combustible dust is in the air under normal operating conditions in quantities sufficient to produce explosive or ignitable mixtures; or (2) where mechanical failure or abnormal operation of machinery or equipment might cause such explosive or ignitable mixtures to be produced, and might also provide a source of ignition through simultaneous failure of electric equipment, operation of protection devices, or from other causes; or (3) in which combustible dusts of an electrically conductive nature may be present. Division 1 locations always require the application of the appropriate dust-ignition proof motor.
- (d) Class II, Division 2 – A Class II, Division 2 location is a location: (1) in which combustible dust will not normally be in suspension in the air in quantities sufficient to produce explosive or ignitable mixtures, and dust accumulations are normally insufficient to interfere with the normal operation of electrical equipment or other apparatus, or (2) dust may be in suspension in the air as a result of infrequent malfunctioning of handling or processing equipment, and dust accumulations resulting therefrom may be ignitable by abnormal operation or failure of electrical equipment or other apparatus. The National Electrical Code specifies Class II, Division 2 motors have no external openings and comply with external surface temperature limits when operating at full-load in free air. The surface temperature limits vary with dust characteristics such as ignition temperature, susceptibility to dehydration and potential for carbonization. The controlling document is ANSI/NFPA 70; material characteristics are detailed in NFPA 497M.

CAUTION: THE RESPONSIBILITY OF SPECIFYING THE PROPER CLASS, GROUP AND DIVISION OF HAZARDOUS LOCATION RESIDES WITH THE ULTIMATE USER AND THE INVOLVED REGULATORY AGENCY.

SPECIAL WINDING TREATMENT

Various winding treatment options and protective coatings are available to provide additional protection in special or extreme application and environmental conditions.

Encapsulated Winding (Frames 320-5013)

Additional protection against moisture is provided by an encapsulated winding. These motors meet NEMA MG1-1.27.1. Totally-enclosed construction is suggested for motors in frames 286 and smaller.

Custom Polyseal® Motors (Frames 400-5013)

These motors have vacuum pressure impregnated windings which have been taped to hold additional varnish and to increase their mechanical strength. Custom Polyseal® motors meet NEMA MG1-1.27.2 and are capable of an underwater submergence test which includes a hipot and megger test.

Abrasion Resistance (320-5013)

These motors can be supplied with an abrasion resistant winding treatment which gives added protection from airborne particles.

MODEL NUMBER NOMENCLATURE

The following nomenclature is the basis for the majority of GE integral-hp motor model numbers. The model number format shown below provides basic descriptive information as follows:

Model:	<u>5</u>	<u>K</u>	<u>215</u>	<u>A</u>	<u>L</u>	<u>205</u>	<u>A</u>	<u>E</u>
Description:	1	2	3	4	5	6	7	8

1. The numeral "5" is used to designate rotating electrical machinery

2. Electrical Type Letters

a. Polyphase:

K	NEMA designs A & B
KAF	Adjustable frequency
KG	NEMA design C
KGS	NEMA design C Energy Saver
KL	Hydraulic elevator
KOF	Oil well pumping
KR	NEMA design D
KS	NEMA design A & B Energy Saver
KY	Special characteristics

b. Single-Phase:

KC	Capacitor start
KCJ	Capacitor start high torque
KCY	Special capacitor start

3. NEMA frame size

4. First form letter

a. Group 1. The following take precedence over all Group 2 letters (except explosion-proof)

M	Marine motors
N	Navy motors
P	Partial motors
T	Textile motors
S	Severe-duty motors

b. Group 2. Are shown in Table 22.

Table 22.

Type	DP	TEFC	TENV or TEAO	Explosion-Proof	WPII
Footed frame and no customer mounting rabbets or auxiliary devices such as brakes	A	B	H	C	E
Round frame and no auxiliary devices such as brakes	D	F	W	G	—
All others	J	K	K	R	—

5. Second form letter

C	Cast iron construction (sourced)
D	Rolled steel, 182-286 frame
E	Cast iron, 182-286 frame
L	Aluminum horizontal (obsolete)
N	Cast iron construction horizontal
P	Aluminum alloy vertical (obsolete)
S	Cast iron horizontal, 320-449 frame
T	Cast iron vertical P-base

6. Form numbers

a. Number of Poles. For horizontal motors, the first digit in the series represents the number of poles divided by 2:

1 = 2 pole

2 = 4 pole

etc.

The number "9" is reserved for multispeed.

b. Nameplate Voltage. The last digit in this series designates input voltage for stock horizontal motors only.

4 = 575 volts

5 = 230/460 volts

6 = 200 volts

8 = 460 volts

7. First suffix letter

Denotes interchangeable design change of the complete motor. If the first suffix letter is present it will be A, B, C, D, D1, D2... or D99.

8. Second suffix letter

Denotes special item or thermal device

a. Special items

F2, W1, W2, W3, W4, W5, W6, W7, W8, C1, C2

b. Thermal devices

S, T, X = Klixon automatic reset

U, W, Y = Klixon manual reset

M = Sensor, thermistor, or RTD

P = Thermostat

ELECTRICAL MODIFICATIONS

CURRENT TRANSFORMER

It is sometimes desirable on larger motors to have current transformers installed in the motor conduit box for operation of auxiliary devices or sensing circuits. Motors in frames 509-5013 can be furnished with single-secondary current transformers in the main or neutral leads. These can include window-type transformers or bar-type transformers to meet the specifications of the user or the control manufacturer and must be fully specified by the customer. Current transformers require an oversize conduit box which must be included in the order.

GROUNDING PROVISIONS

Special grounding provisions can be supplied in the conduit box for mounting in the drive end endshield.

The special conduit box grounding provision consists of a brass stud in place of one of the conduit box mounting screws. Also included are two jam nuts for mounting to an external ground lead.

Hardware for the endshield grounding option is shipped as a kit including a brass stud, nut and washer. The stud is assembled in place of one of the endshield bolts.

LEADS, SPECIAL

All motors are provided with standard leads of ample length for easy connection in the conduit box to the power leads. Lead size and material are dependent upon the class of insulation system in the motor and the current capacity required. Longer than standard leads are available.

STARTING CURRENT, LOWER THAN STANDARD

The starting current code (KVA-per-horsepower) for polyphase 60 Hz motors in the integral-hp sizes is code G. Reducing the amount of starting current to code F limits or lower may require more material, increased frame size or a combination of these factors. Starting torque and breakdown torque may also be reduced to less than NEMA design B limits.

SURGE PROTECTION

Surge protection capacitors and lightning arrestors can be supplied on 500 frame motors as a package in an oversize conduit box for mounting adjacent to the motor.

TEMPERATURE RISE, SPECIAL

NEMA has defined allowable winding temperature rise according to class of insulation and maximum ambient temperature. Where there are requirements for special low winding temperature rise, please contact the Company for review of the available options.

TERMINALS, SPECIAL

All motors with AWG #12 or larger leads are supplied with "AMP" ring terminals similar to Figure 24. "Burdny Hydent" terminals can be supplied on motors in frames 284 and larger on request.

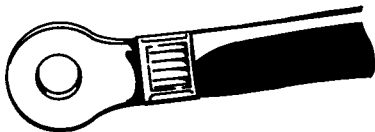

Figure 24. Amp Ring Terminal

Motors with AWG #14 or smaller leads will be supplied with lead wire stripped for connection to power leads.

THERMAL PROTECTION

The following devices are applicable only to motors with class B or F insulation.

Built-in protective devices to prevent motor overheating may be either: (A) Line interrupting devices which open the power supply when the motor overheats or (B) pilot devices. The latter open the holding coil circuits of a magnetic switch to take the motor off of the line, or energize alarm bells or warning lights. Motors taken off line by pilot devices typically cannot be restarted until an operator recloses the magnetic starting switch.

A. Line-Interrupting Devices – Current-Sensing Thermal Protectors

These protectors sense both motor temperature and current and offer inherent protection against all abnormal stalled and running conditions. They are built into the motor conduit box for automatic* reset operation on three-phase dripproof motors 182-184 frames and for both automatic* and manual-reset operation on single-phase motors 182-215 frame.

These protectors are not available on explosion-proof motors or on two-winding multispeed motors.

***WARNING: A MOTOR WITH AUTOMATIC-RESET THERMAL PROTECTION SHOULD NEVER BE USED WHERE AN UNEXPECTED RESTART MAY INJURE PERSONNEL OR DAMAGE PROPERTY.**

B. Pilot Devices

(1) Thermostats

Thermostats are mounted on the stator winding and are temperature-sensing only. They are available with normally open or normally closed contacts and only for automatic reset.

Thermostats will protect the motor from high ambient temperature, exceedingly long accelerating cycles (where the design is not rotor limited), repeated or excessive overloads and loss of ventilation. However, they do not give protection under stalled or locked-rotor conditions and must be used with an external current-sensitive motor control for complete motor protection.

Thermostats can be installed in all motor enclosures. They are not recommended for machines with nameplate voltages exceeding 600 volts.

Thermostats are suitable for the following pilot circuits:

Power Supply	Voltage	Current
AC	110-115 volts	6.0 amp
AC	220-230 volts	3.0 amp
AC	440-480 volts	1.5 amp
AC	550 volts	1.2 amp
DC	115-125 volts	2.2 amp
DC	230-250 volts	1.1 amp
DC	550 volts	0.4 amp

(2) Thermistors

Thermistors are small non-linear resistance devices placed in the stator windings. As the critical temperature is reached, the resistance of the thermistors changes radically, causing operation of a control relay. Normally, 3 thermistors are furnished, one per phase. Thermistors may be furnished with or without a separate (greater than 600 nameplate volts) control relay. Thermistors are not recommended on high voltage encapsulated or Custom Polyseal® machines.

(3) Resistance Temperature Detectors

RTD's are precision wire-wound resistors with calibrated temperature-resistance characteristics. These devices are used in conjunction with customer supplied instruments and are available in 10, 100 and 120 ohm designs. Normally six RTD's (2 per phase) are furnished per motor, suitably distributed around the circumference of the stator winding, located between coil sides and positioned to detect the highest slot temperature.

MECHANICAL MODIFICATIONS

BEARINGS – THERMAL PROTECTION

Bearing thermal protection is available on 509-5013 frame motors and is most practical for sleeve bearing machines. Bearing temperature relays or temperature detectors can be provided to either operate an alarm system or indicate temperature levels. The customer must specify the type of system required and whether temperature indicators are to be furnished by General Electric.

BRAKES

Brakes supplied mounted on motors will be disc-type, spring set electrically released brakes manufactured by either Stearns Electric Corp. or by Dings Brakes, Inc. at General Electric Company option. Brakes are available for motors in frames 182- 449 only.

Several factors must be considered when determining the correct brake for a particular application.

1. Brake Torque

As a general rule of thumb, the torque rating of a brake should, as a minimum, match the full-load torque of the motor on which it is mounted. This will provide ample torque if the brake is used for holding and will also provide a stop in approximately the same time as required for acceleration. Full-load torque can be calculated as follows:

$$\text{Full-Load Torque} = \frac{5252 \times \text{Hp}}{\text{Full-Load Speed}}$$

For applications involving high inertia load, fast stops or a stop within a given time limit, the brake should be selected on the basis of total inertia to be retarded. Brake rating may be calculated as follows:

$$\text{Torque} = \frac{WK^2 \times \text{RPM}}{308 \times t}$$

Where: WK^2 = Load inertia in lb-ft²
RPM = Full-Load Speed in rpm
t = Time, in seconds, to stop

Standard brake torque ratings or continuous duty include: 6, 10, 15, 25, 35, 50, 75, 105, 125, 175, 230, 330, 440, 550 pound-feet. If the calculated brake torque falls between the standard torque values, specify the next higher torque.

2. Brake Voltage

Brakes are supplied for operation on the same voltage as the motor unless otherwise specified. In the case of dual voltage motors, brake voltage will be the lower of the motor voltages, unless otherwise specified. Standard brake voltages are:

60 hertz 200, 230, 460, 575 Volts
50 hertz 200, 220, 380, 415, 440, 550 Volts

Stearns brakes are all single-phase. Dings brakes are single-phase up to 9 lb-ft and three-phase in larger ratings.

Brake leads are terminated at a conduit connection on the brake.

3. Brake Enclosure

Brakes are available in enclosures to match the needs of the environment in which they will be operating. Standard enclosure is for application on dripproof or totally-enclosed fan-cooled motors for indoor or semi-protected outdoor installations. Dust-tight, waterproof enclosure is suitable for severe-duty and totally-enclosed motors used in conditions of extreme moisture, abrasive or conductive dusts, acid or alkali fumes or for outdoor installation.

4. Vertical Mounting Position

Brakes must be specially modified for vertical mounting. Specify if the motor will be above or below the brake.

CONDUIT BOX, SPECIAL

Standard conduit boxes meet or exceed NEMA and NEC volumes and are adequate for connecting all necessary leads for power and any incidental control circuits.

Available options for motors in frames 182 through 449 include extra 3/4" conduit hole for dripproof TENV and TEFC motors, additional conduit box, waterproof conduit box and oversize box.

Motors in frames 509-5013 are available with a 2500 cubic inch motor mounted box suitable for stress cone connections or for mounting accessory equipment. This special box is furnished as standard for all motors of 3000 volts and above. Three stand-off insulator-supported copper bar terminations for motor leads can be furnished if specified. An 11,000 and a 17,000 cubic inch motor mounted conduit box are available. In addition, a 44,000 cubic inch floor mounted, conduit box is available to mount beside the motor with conduit connection to the motor frame. This construction allows the customer to mount accessories such as current transformers, surge capacitors, lightning arrestors, etc.

COUPLINGS

Motors are normally furnished without couplings; however, a one-piece half coupling can be installed on the motor shaft at the factory providing it is balanced, finished machined and key-seated to motor shaft dimensions. It must be shipped prepaid to the factory of motor manufacture before the start of production. Motors are dynamically balanced prior to installing the half coupling and are not rebalanced after coupling assembly.

A vibration test with half-coupling installed will be performed and a test report issued when this special service is requested by the customer and included in the quotation.

DOWEL HOLES IN FEET

Dowel holes are furnished as standard on 500 frame motors as an alignment aid. One 1/2 inch hole is provided in each of the diagonally opposite feet.

ENDSHIELDS, SPECIAL

Horizontal motors are available with Type C face, and D flange endshields, which have rabbets and bolt holes for mounting equipment to the motor, or for over hanging the motor on a driven machine. The Type C face endshield provides a male rabbet and tapped holes for mounting bolts. This endshield is used for mounting small apparatus, such as pumps, to the motor. The Type D flange has a male rabbet, with holes in the flange for through bolts. This flange is primarily used on machine-tool gear boxes.

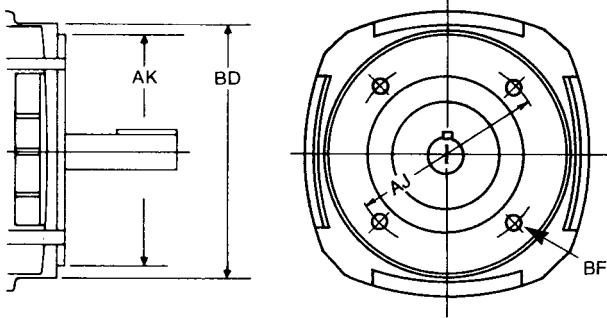

Figure 25. Type C-Face

Table 24. C-Face Mounting Dimensions (inches)

Frame Size	Face Diameter	Rabbet Diameter	Bolt Circle	Bolt Holes	
	BD	AK	AJ	BF	Tap Size Min. Depth
Dimensions in inches					
182-184	8.50	8.50	7.25	.50-13	.75
213-215	8.68	8.50	7.25	.50-13	.88
254-256	8.68	8.50	7.25	.50-13	.88
284-286	10.75	10.50	9.00	.50-13	.88
324-326	12.75	12.50	11.00	.625-11	1.06
364-365	13.00	12.50	11.00	.625-11	1.06
404-405	13.00	12.50	11.00	.625-11	1.06
444-449	17.50	16.00	14.00	.625-11	1.06

Note: Frame 182 through 326 have 4 holes; 364 and larger have 8 holes

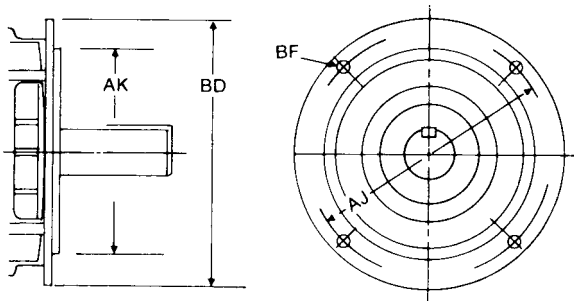

Figure 26. Type D-Flange

Table 25. D Flange Mounting Dimensions

Frame Size	Flange Diameter	Rabbet Diameter	Bolt Circle	Bolt Holes
	BD	AK	AJ	BF
Dimensions in inches				
182-184	11.00	9.00	10.00	.53
213-215	11.00	9.00	10.00	.53
254-256	14.00	11.00	12.50	.81
284-286	14.00	11.00	12.50	.81
324-326	18.00	14.00	16.00	.81
364-365	18.00	14.00	16.00	.81
404-405	21.90	18.00	20.00	.81
444-449	21.94	18.00	20.00	.81

NOTE: Frames 182 through 365 have 4 holes. 404 and larger have 8 holes.

FRAME, NON-STANDARD

Requests are occasionally received to furnish motors in frame sizes either larger or smaller than NEMA standard. If frame size larger than standard is to be supplied, the standard motor rating for that frame size will be furnished. If smaller than standard frame is required, please contact Company for feasibility and terms.

GREASE & RELIEF FITTINGS

Motor with regreaseable bearing systems can be supplied with regrease fittings and automatic grease relief devices. Severe duty motors are supplied with extended hydraulic grease fittings and plugs.

SHAFTS, SPECIAL

Motors are furnished with a single straight shaft with sled runner keyway and a rectangular key. For motors in frames 182 through 449, a long shaft for V-belt drive is supplied for a majority of ratings and is denoted by the suffix 'T' or 'L' on the motor frame size. Two-pole (3600 rpm) motors in frames 284 through 449 and certain other 449 frame ratings are furnished with short shafts for direct connection. These motors are denoted with the suffix "TS", "LL" or "LS" on the motor frame size. Standard double-end shaft extensions are available for motors in frames 182 through 5011.

Special shaft designs are available including differences in dimensions and/or materials as follows:

Length: Up to 10 inches longer than standard for motors in frames 182-449.

Up to 13 inches longer than standard for motors in frames 509-5013.

Longer than standard shafts are usually suitable for direct connection. Other drives such as belts or gearing may require special bearings and should be referred to Company.

Keyway: Sled-runner, round end, or Woodruff #3 or #9

Hole: Drilled radially or in the end of the shaft. Drilled and tapped in the end of the shaft. Hole depth limited to three times the hole diameter 26.

Steps: One or more reductions in shaft diameter.

Threads: Class 2A right-hand thread of size appropriate to the shaft diameter.

Squared: Milled flats on four sides of one step.

Tapered: 1 1/4 or 1 1/2 inch per foot taper with threads, nut and lock washer.

ENVIRONMENTAL MODIFICATIONS

ALTITUDE

The rating of standard motors assumes operation at sea level in a 40°C ambient. For purposes of standardization it is considered that there is no difference in motor operating temperature between sea level and 3300 feet altitude.

The cooling effect of ventilating air is a function of its density. The atmospheric pressure and density at higher altitudes is reduced and the air cannot remove as much motor heat, causing the motor to run hotter. As a general guide, motor temperature rise increases 1% for every 330 feet above 3300 feet. To keep motor heating within safe limits at altitudes above 3300 feet, there are the following alternatives:

- A. Supply a motor designed for standard sea level operation which can either be:
- (1) Operated at less load (a motor with service factor rating of 1.15 or higher can be operated at altitudes up to 9000 feet with a 1.0 service factor), or
 - (2) Operated in a lower ambient temperature per the following table:

Table 26.

If Ambient Temperature is:	Max. Altitude with Same Service Factor is:
30° C	6600 ft.
20° C	9900 ft.

It should be remembered that, although the outdoor ambient temperature at higher altitudes is low, motors probably will be installed indoors in higher ambient temperatures.

Motors applied per A(1) or A(2) above, will have no special altitude or temperature data on the nameplate.

- B. Supply a special motor designed for the required high altitude operation, with appropriate data stamped on the nameplate.

HIGH AMBIENT, POLYPHASE

Standard motors are designed so that the temperature rise produced within the motor, added to the standard 40°C ambient temperature, will not exceed the winding-insulation temperature limit. If the ambient temperature exceeds 40°C:

- A. The temperature rise produced in the motor must be offset by:
- (1) Reducing the load and consequent motor losses. A motor rated for a 40°C ambient temperature and operating in a 50°C ambient, will, if rated 1.15 service factor, carry rated hp with no overload (1.0 SF) and, if rated 1.0 service factor, carry 90% of rated hp, or by...
 - (2) Applying a special motor design.
- B. The temperature limit may be raised by the substitution of a higher-temperature insulation system, special grease and bearings.

Motors applied per A(1) above will not have special ambient temperature or service factor data on the nameplate.

The choice between A(2) and B rests with the motor designer who also may have to use a frame size larger than is standard for the rating. Explosion-proof motors may require frame sizes different from the corresponding totally-enclosed motors.

WARNING: THE MAXIMUM ALLOWABLE AMBIENT TEMPERATURE FOR EXPLOSION-PROOF MACHINES IS 60°C.

HIGH AMBIENT, SINGLE-PHASE

For operation in ambient temperatures higher than 40°C, refer to Company giving full details of the application.

LOW AMBIENT

For operation in ambient temperatures of less than minus 40°C, give full details of the application. Special low-temperature grease and special steel shafts may be required.

DRIP COVERS (WALL OR VERTICAL MOUNTING)

Drip covers can be furnished on standard horizontal motors for added protection from dripping liquids and falling objects when the motor is mounted in other than the normal horizontal position.

If dripping liquids are present in the application, protective covers are recommended for dripproof construction motors mounted shaft up or shaft down.

EXPORT BOXING AND PACKING

Export boxing and packing should be specified when a motor, and/or spare parts, are to be furnished for export shipment.

GREASE, SPECIAL

Motors designed for unusual environmental conditions or special duty should have bearing grease selected for such service. The most commonly encountered conditions requiring special lubricants are extremely high or low operating ambients. The majority of motor greases used by GE Motors are suitable for operation at ambient temperatures from minus 40°C to plus 40°C.

HARDWARE

Standard motor hardware has a plated protective coating suitable for the corrosive atmospheres generally encountered. For extremely corrosive atmospheres, stainless hardware may be required, and should be specified.

PAINT

Standard Finishes

Motors are protected by a two coat paint system. The first coat is a rust-inhibitive primer applied to protect the castings during storage and manufacture. The second coat is a medium light gray or buff semigloss paint.

Most commercially available paints are compatible with the paint system described above. It is recommended that the customer apply any finish coat over the motor paint in his plant when the driven equipment is painted.

SCREENS

Intake and Discharge Screens – Dripproof Guarded

Corrosion resistant screens can be furnished over the air- intake and discharge openings of dripproof motors. Dripproof motors equipped with these screens conform to the “dripproof guarded” definition appearing in NEMA MG1, Part 1.

Rodent Screens – Rodent screens will be provided where required as part of the dripproof guarded system and on specific request of the purchaser.

SEALS, SHAFT

The following tabulation lists the sealing arrangement where shafts emerge from the motor bearing housings.

Table 27. Shaft Seals

Motor Enclosure	Motor Frame	
		182
	449	5011
Shaft Seal		
Standard Dripproof	F	F
Enclosed	F	F
Severe-duty Enclosed	S	S
Explosion-proof	F*	F*

F = Close running fit at both ends.

S = Neoprene slinger steel reinforced DE only.

* Except Class II, Group E motors which have non-sparking labyrinth seals.

SPECIAL AND DEFINITE PURPOSE APPLICATIONS

CLOSE-COUPLED PUMP MOTORS

Description:

These motors are designed to meet the requirements of motor mounted centrifugal pumps.

Product Line:

NEMA Design	B (GE Types K and KC)
Enclosure	Dripproof or Totally-enclosed fan cooled
Frames	182-365
Voltage	200, 230, 460, 575
Frequency and Phase	60 hertz, 3-phase or single-phase
Ambient	40°C Dripproof, 1.15 Service Factor 40°C TEFC, 1.15 Service Factor
Ratings	1 through 60 Horsepower

Standard Features:

Motors feature a NEMA Type "C" face endshield and a standardized shaft extension on which the pump casing and impeller are mounted. Machining is to close axial and radial tolerances. Motor dimensions for this compact assembly are per the NEMA "JM" and "JP" standards established in conjunction with the pump industry. Standardization permits a high degree of interchangeability of pump and motor sizes; special pump parts are held to a minimum.

ENERGY SAVER® EXTRA SEVERE-DUTY MOTORS

Description:

The XSD™ line of premium efficiency motors is designed especially to operate in the rugged environments found in the process industries such as chemical, petroleum, plastic, paper, metals and cement. These extra severe-duty motors are well suited for a wide variety of applications including pumps, compressors, fans, blowers, materials handling equipment and drives for special process machinery – wherever premium efficiency, reliability and long life are a basic requirement of the application.

Product Line:

NEMADesign	B and C (GE Types KS and KGS)
Enclosure	TEFC Extra Severe-Duty Explosion-Proof, Extra Severe-Duty
Frames	182-449
Voltage	230, 460 or 575 Volts
Frequency and Phase	60 hertz, 3-phase
Ambient	40°C, 1.15 Service Factor
Ratings Available	3-250 Hp, 3600 rpm 3-250 Hp, 1800 rpm 1.5-200 Hp, 1200 rpm 1-150 Hp, 900 rpm

XSD™ Features:

As a result of careful reviewing of the special needs of the process industries, motors in this product line include many unique features. XSD™ motors have a bearing life (L_{10a}) of 50,000 hours for belted applications.

All XSD™ motors have bearing life (L_{10a}) of 50,000 hours. Lower motor temperature provides a cooler operating bearing system which significantly increases grease life. The combination of the better bearings and long life grease improves motor reliability and reduces maintenance costs. Motors are equipped with regreasable antifriction bearings with readily accessible inlet hydraulic grease fittings and Allen head outlet plugs for convenient relubrication.

Motors are dual-rated with a service factor of 1.15 in a 40°C ambient or 1.0 in a 65°C ambient. Premium efficiency provides extra thermal margin, often allowing these motors to be used on adjustable speed drives without derating. The extra margin also provides protection against momentary conditions of overloads, voltage fluctuations, single-phasing and stall. Thermal margin can be utilized to meet the needs of duty cycle loads. XSD™ motors are available with NEMA design B (normal) or NEMA design C (high) starting torque.

Cast-iron frame and endshield construction is used for these totally-enclosed fan-cooled motors. All external parts are protected by epoxy paint or equivalent. The stainless steel motor nameplate provides complete motor data including efficiency values and bearing numbers. All hardware is corrosion resistant.

The conduit box gasket is fully gasketed with a nipple lead gasket between the box and motor frame and another between the cover and box. Further protection of internal parts is provided by an external slinger on the motor shaft which helps prevent moisture from seeping along the shaft into the motor.

Motors are built with a full class F insulation system using non-hygroscopic materials throughout to resist moisture and help extend thermal endurance. Air gap surfaces are protected against corrosion.

Safety features include a grounding stud in the conduit box plus built-in lifting lugs for easy installation and maintenance. All XSD™ motors have CSA approval.

HYDRAULIC ELEVATOR MOTORS

Description:

Type KL hydraulic elevator motors are specifically designed and manufactured for best performance and long trouble-free life in hydraulic elevator duty. Light weight and compact design make Type KL motors easy to install and service. The low inertia rotor and special electrical design give inherent, smooth, rapid response on the elevator duty cycle.

Product Line:

NEMA Design	B (GE Type KL)
Enclosure	Dripproof
Frames	182T-364T
Voltage	200, 230/460, 575
Frequency and Phase	60 hertz, 3-phase
Ambient	40°C, 1.15 Service Factor
Ratings	3 through 75 Hp 3600, 1800 rpm

Standard Features:

Type KL elevator motors are designed to provide the high torques and maximum full-load speeds demanded by good elevator performance. Motor noise is minimized by special design cooling fans and tight limits on dynamic balance. Standard KL motors are designed for 80 starts per hour or 120 starts per hour in elevator service. More starts per hour or higher than normal inertia pumps can be accommodated when specified.

Regreasable ball bearings, rust-inhibiting lithium or polyurea base grease and the use of vacuum degassed steel bearings increase motor bearing life.

The system uses a large, enclosed bearing housing with long, close-running fits that prevent the entrance of dirt and other contaminants.

The stator core is pressed into the frame and pinned in place to assure a rigid unit even when required to perform a maximum number of starts per hour.

Standard voltages are 200, 230/460 and 575. Motor leads are brought out suitable for connection for wye-delta starting.

Most applications require a dripproof enclosure, the standard enclosure for Type KL motors. Totally-enclosed and explosion-proof enclosures are available.

Application Information:

The four major application considerations for hydraulic elevator motors are: external inertia, starts per hour, percent time on and load variations throughout an operating day.

For typical hydraulic elevator applications requiring normal motor winding insulation life, the following duty cycle has been calculated:

1. Rated voltage at motor terminals, 40°C motor ambient.
2. 30 percent time on, 80 or 120 starts per hour for three hours per day, 5 1/2 days per week.
3. Control selection based on a NEMA 30 minute motor rating.
4. Motor load and driven inertia as defined by Figs. 27 through 30.

Use of a belted drive on a low inertia screw-type pump is almost universal above 10 Hp since belting minimizes the number of motor and pump ratings. A disadvantage of belting is the inertia of belts and sheaves (in the order of three or four times the motor inertia) must be accelerated during each motor start. Figs. 27 through 30 provide a simple means to compensate for the significant effect of accelerating this inertia.

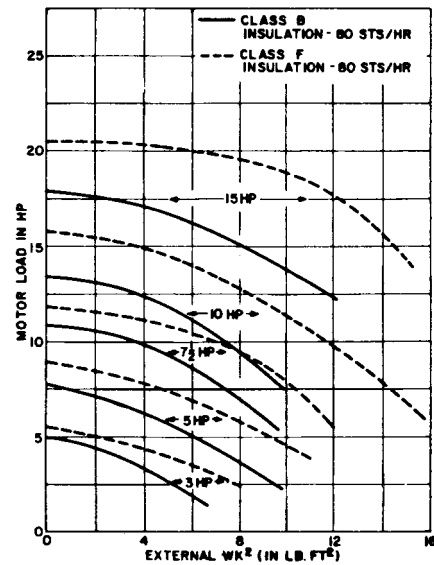

Figure 27.

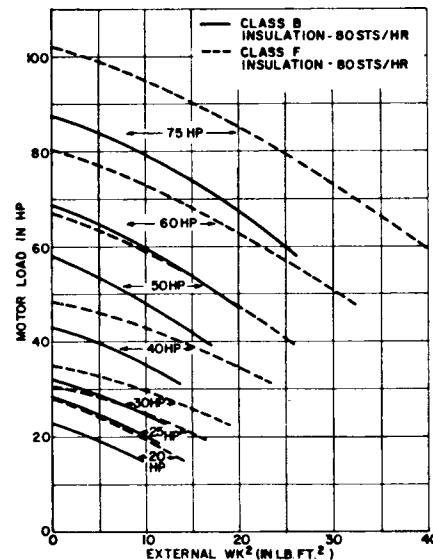

Figure 28.

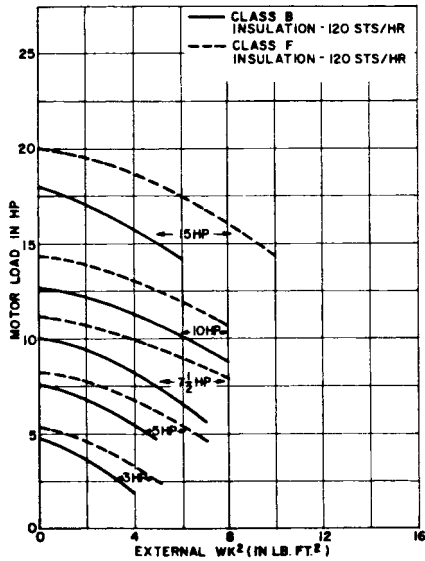

Figure 29.

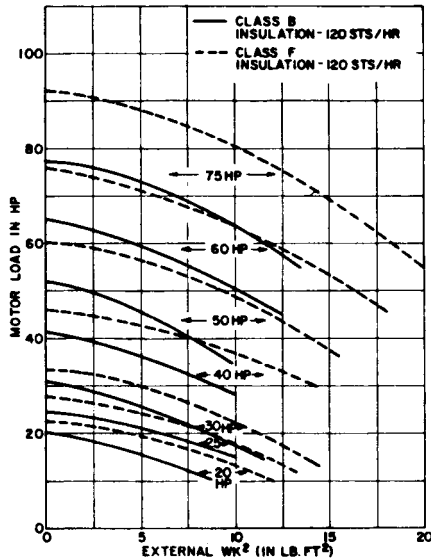

Figure 30.

INJECTION MOLDING MACHINE MOTORS

Description:

General Electric injection molding machine motors meet the rigorous duty cycles imposed by plastic molding under varying load conditions.

The motors are available in 1200 rpm ratings and have normal starting torque. A choice of breakdown torque is given in the range from 250 percent to 400 percent. Through careful duty cycle analysis of specific molding machine requirements, the most economical drive can be selected.

Special construction features maximize the period between scheduled maintenance, and result in high reliability and long life. Optional features for special service conditions are available.

Product Line:

NEMA Design	A
Enclosure	Dripproof Totally-enclosed fan-cooled
Frames	182-449
Voltage	230, 460 or 575
Frequency and Phase	60 hertz, 3-phase
Ambient	40°C, Maximum Ratings 5-100 Hp, 1200 rpm

Standard Features:

1. Special breakdown torques. Injection molding machine motors generally operate under a varying duty cycle load. Therefore, motors should be sized based upon a thermal horsepower calculation and maximum torque requirements.
2. Single or double end NEMA Type C face construction is available.

MULTISPEED MOTORS

Description:

Multispeed motors are applied where operation at two, three or four definite speeds is desired. The motors are classified as to the relation of full-load torques at rated speeds: i.e., constant torque, variable torque and constant horsepower.

Product Line:

NEMA Design	NEMA design does not apply for multispeed motors (GE Type K, KS)
Enclosure	Dripproof or Totally-enclosed, explosion-proof fan-cooled
Frame	182-5011
Voltage	200, 230, 460, 575
Frequency and Phase	60 hertz, 3-phase
Ambient	40°C, Dripproof, 1.15 Service Factor; 40°C, TEFC, 1.0 Service Factor
Rating	1 through 800 horsepower •One winding, two winding •Variable torque, constant torque and constant horsepower •2 speed, 3 speed, 4 speed

Application:

Different speeds are obtained by switching electrical connections. The speed on each connection has the constant speed characteristic typical of single-speed induction motors. Multispeed motors may have a single reconnectable winding or two independent windings.

It is possible to arrange a *single winding* so that it can be reconnected for a different number of poles (and speed) by suitable reconnection of the leads. However, such an arrangement will permit only two speeds and *the speeds must be in the ratio of two-to-one*.

An alternate way of securing two speeds is to have *two separate windings*, each wound for a different number of poles and speed. Such an arrangement means that one winding is not in use when the other is connected to the line; motor frame sizes usually are larger in order to accommodate the idle winding. But the use of two windings permits two speeds which are not in the ratio of two-to-one. Speeds with a two-to-one ratio can be delivered by two-winding motors as well as by single-winding motors.

The choice between one winding, and two winding motors is affected by the speeds desired, the motor price, the control price, wiring complexity and physical size. One winding motors have lower prices than two winding motors but usually require more expensive controls.

A four-speed motor has two windings and each winding is arranged for two speeds having a two-to-one ratio. If one of the two windings is single speed, the motor has a total of three speeds. A motor with three windings, which would permit speed combinations like 1800/1200/720 rpm, is not a practical design.

Multispeed motors are classified by the relation of the full-load torques at the two (or more) full-load speeds.

If the motor has the same full-load torque at both speeds, the motor is a *constant torque motor*. Since constant torque motors have the same full-load torque at both speeds, the horsepower ratings for the two speeds are in the same ratio as the speeds. For example, the low speed rating of a 10 Hp 1800/900 rpm constant torque motor is 5 Hp.

If the full-load torques are in the same ratio as the speeds, the motor is a *variable torque motor*. The horsepower at the low speed, involving both reduced torques and reduced speed, compares to the high speed in ratio of the square of the speeds. Therefore, in the case of a 10 Hp 1800/900 rpm variable torque motor, the low speed horsepower is 2 1/2 using the following equation:

$$Hp_{Low} = Hp_{Hi} \left(\frac{RPM_{Low}}{RPM_{Hi}} \right)^2$$

If the full-load torque values at the two speeds varies inversely to the speed, the motor is designated constant horsepower.

The horsepower listing of multispeed motors always applies to the highest speed. The horsepower ratings at the lower speeds are determined by the particular speed and the motor's torque classification. Motor horsepower is a direct function of both torque and speed.

For each speed of a multispeed motor, the horsepower rating must be equal to, or greater than, the horsepower required by the driven load at each speed.

Constant-torque motors are used on friction type loads, or where the work being done is in direct proportion to the speed. Typical examples of constant torque loads are conveyors, escalators and positive displacement pumps or compressors.

Variable torque motors are normally applied to fans centrifugal blowers and centrifugal pumps which put a horsepower load on the motor which varies as the cube of the speed. If the motor output is adequate for the high speed load, it is sure to have enough Hp at the lower speeds since the motor Hp reduces only as the square of the speed.

Constant horsepower motors are applied on machines that must handle a heavier weight or a greater cut (machine tools) on lower speed than on high speed. For example, a metal-cutting lathe would use the high-speed connection for a light finish cut, but the low-speed connection for taking off large chips in a rough cut.

Multispeed ratings may have lower starting torques than the corresponding single speed ratings.

Multispeed motors are connected in various ways requiring special control, whether manual or magnetic, for starting, changing speeds and stopping. Since the full-load current for high speed is different from that for the lower speeds, separate independent thermal overload relays with correctly selected heaters are required in the control to completely protect the motor on all speed connections.

An alternate is to specify multispeed motors equipped with heat-sensing protectors, built into the winding to positively prevent burnouts caused by overloads, stalling, lack of ventilation, single-phasing or unbalanced voltages regardless of speed, winding connection or ambient temperature.

Multispeed motors are supplied for a single voltage. Motors larger than 365T frame are not furnished for voltages below 460 volts at 60 hertz (380 volts at 50 hertz).

Multispeed motors may be started on any speed either on full voltage, or on reduced voltage by resistor, reactor or autotransformer starters. They are not available for wye-delta or part winding starting.

OIL WELL PUMPING MOTORS

Description:

Type KOF motors have special performance characteristics particularly suited to the requirements of beam drives for oil well pumping.

Product Line:

NEMA Design	D (GE Type KOF)
Enclosure	Dripproof Guarded
Frame	213T through 449T
Voltage	460/796 at 1200 rpm; 230/460 at 900 rpm
Frequency and Phase	60 hertz, 3-phase
Ambient	40°C, 1.0 Service Factor
Rating	3 through 125 Horsepower

Standard Features:

The construction of these motors is mechanically strong and resists corrosion. Rodent screens are standard on all ventilating openings. The motors have an encapsulated varnish system and are ideal for rugged outdoor service in the oil fields.

Electrically, the oil well pumping motor has high slip and high torque to assure lower kw-hr per barrel. Type KOF motors are designed to deliver ideal torque and slip characteristics at the high voltage (460/796 volts) normally available from oil field distribution systems.

TOTALLY-ENCLOSED AIR-OVER (TEAO)

Description:

Totally-enclosed air-over (TEAO) motors are specifically designed for fan and blower applications where the air being moved passes directly over the motor frame to cool the motor. Motor ratings can be selected based upon velocity of cooling air over the motor frame. It is often possible to select a smaller frame for a given load resulting in cost and space savings. Motor thrust capability ratings assume a fan mounted on the motor shaft. The motors can be belt connected to the fan or blower as long as an adequate velocity of air flows directly over the motor. The totally-enclosed construction prevents moisture, dust and other contaminants from entering the motor from the air stream.

Product Line:

NEMA Design	B (GE Type K, KS)
Enclosure	Totally-enclosed air-over
Frames	182-405
Voltage	200, 230, 460 or 575 Standard
Frequency & Phase	60 hertz, 3-phase
Ambient	40°C, Maximum
Ratings	See Table 29

Selection:

The horsepower required by the fan should be determined based on handling "standard" air at 70°F temperature with a density of 0.075 pounds per cubic foot.

Minimum air velocity in feet per minute listed in Table 29 must flow directly over the motor frame for continuous operation at rated horsepower.

The air velocity along the motor is affected by fan design factors such as:

1. Fan hub dimensions relative to motor frame diameter.
2. Fan hub diameter relative to fan blade diameter.
3. Position of the motor in the air stream.
4. Method of mounting motor (feet, face, flange, etc.).
5. Characteristics of air flow (turbulent laminar, etc.).

In view of these factors and other potential variables, the fan manufacturer has the ultimate responsibility for proper motor selection and applications.

Thrust values in Table 29 assume maximum fan weight and represent the maximum permissible thrust to provide a 14 year average bearing life and a 25,000 hour L_{10} life in accordance with AFBMA bearing life calculations.

Fan weight shown is the maximum weight of a fan in "commercial balance", concentrated at the end of the motor shaft extension, which is permissible for safe shaft and bearing loading. A fan has commercial balance if its unbalance moment in ounces-inches (the weight in ounces times the distance in inches from the axis of rotation required to produce perfect balance) is numerically equal to, or less than, one percent of the weight in pounds of 1200 rpm and higher speed fans or five percent of the weight in pounds of lower speed fans.

Vertical mounting applications (shaft up or down) should be referred to Company to determine whether drive-end bearing should be clamped.

Table 29. Totally-Enclosed Air-Over Motor Application Data

Rated Hp	RPM (Sync)	Frame	Class B Insulation		Max. Thrust Pounds		Max. Fan Wt. (lbs)
			Min Air Velocity (Ft per min) at Rated Hp	Toward Motor	Away From Motor		
1	900	182T	100	235	170	190	
1.5	1200	182T	100	210	140	190	
	900	184T	150	235	170	190	
2	1200	184T	100	210	140	190	
	900	213T	200	415	330	250	
3	3600	182T	100	130	90	130	
	1800	182T	100	160	105+	190	
	1200	213T	300	365	280	250	
	900	215T	500	415	330	250	
5	3600	184T	200	130	90	130	
	1800	184T	300	160	105+	190	
	1200	215T	150	365	280	250	
	900	254T	350	680	470	535	
7.5	3600	213T	800	245	185	165	
	1800	213T	800	325	230	250	
	1200	254T	300	625	395	535	
	900	256T	650	680	470	535	
10	3600	215T	1500	245	185	165	
	1800	215T	1500	325	230	250	
	1200	256T	800	625	395	535	
	900	284T	300	770	505	690	
15	3600	254T	1800	405	345	165	
	1800	254T	1100	485	340	420	
	1200	284T	600	735	435	690	
	900	286T	700	770	505	690	
20	3600	256T	2000	405	345	165	
	1800	256T	900	485	340	420	
	1200	286T	800	735	435	690	
	900	324T	600	1005	665	860	
25	3600	284T	1500	460	410	165	
	1800	284T	1200	610	390	540	
	1200	324T	800	975	575	860	
	900	326T	800	1005	665	860	
30	3600	286T	1500	460	410	165	
	1800	286T	1200	610	390	540	
	1200	326T	800	975	575	860	
	900	364T	900	1330	860	1070	
40	3600	324T	1800	625	545	215	
	1800	324T	1500	785	455	800	
	1200	364T	1000	1235	720	1070	
	900	365T	1000	1330	860	1070	
50	3600	326T	2600	625	545	215	
	1800	326T	1500	785	455	800	
	1200	365T	900	1235	720	1070	
	900	404T	1000	1670	1060	1200	
60	3600	364T	1800	810	670	315	
	1800	364T	1700	995	555+	1070	
	1200	404T	800	1465	860	1200	
	900	405T	600	1670	1060	1200	

+Actual L_{10} = 23,000 hrs.

NOTE: For given thrust, bearing L_{10} is a minimum of 25,000 hrs. unless otherwise noted.

ADJUSTABLE SPEED DRIVE OPERATION

PRODUCT

NEMA Design does not apply (GE Type KAF)

Enclosure: Open dripproof or totally-enclosed

Frames: 320-5011

ADJUSTABLE SPEED DRIVE (ASD) OPERATION

To determine whether a standard motor can be used on an ASD, the load needs to be plotted against the motor's capability. Refer to publication GET-8035 "Standard AC Induction Motor Capability Curves" for curves on our standard line of motors at Class F motor temperature rise on the ASD. If B motor temperature rise on the ASD is required, refer to the Company.

If a special motor is to be ordered, two lines of motors are available: KAF designs in standard constructions (ODP, TEFC or TEFC - Severe-Duty), or KAF designs in special ASD construction. The ASD construction features motors specially designed for wide constant torque speed ranges with tachometer mounting capability and are featured in publication GEP- 9012 "Buyer's Guide Adjustable Speed AC Induction Motors". These motors are available in severe-duty or explosion-proof construction.

When applying a motor to an ASD, the following information needs to be supplied in addition to the normal requirements (voltage, Hp, construction, etc.):

ASD/LOAD REQUIREMENT DATA SHEET

VARIABLE FREQUENCY OPERATION:

Design Point _____ Hp, @ _____ RPM;

Range (Min.-Max.) _____ - _____ RPM

Type Load _____ Constant Torque _____ Variable Torque

(Above Design RPM, _____, Constant Hp, _____ CTq _____ VTq)

ASD Type: _____ PWM (Pulse Width Modulated)

_____ VSI (6 Step Voltage Inverter)

_____ CSI (6 Step Current Inverter)

Make _____, Model # _____

Fill out only the applicable requirements below:

Service Factor (Sine Wave) _____ (ASD) _____

Temp Rise (Sine Wave) _____ (ASD) _____

Overload (150% for 1 Minute Standard): _____

Starting Torque (140% Rated Torque with 150%

Rated Current Standard): _____

Is NEMA A Design Acceptable If Required to Keep in NEMA Frame?
(Will have higher inrush. May be undesirable if inverter bypass is required.) _____

REFERENCES

National Electrical Code® and NEC®, terms used throughout this publication are Registered Trademarks of the National Fire Protection Agency, Inc., Quincy Mass.

NEMA Standards Publication No. MG1 –1993
National Electrical Manufacturers Association
2101 L Street, N. W.
Washington, DC 20037

Notes:

We bring good things to life.



GE Industrial Systems
